

# LIQUID CRYSTAL DISPLAY MODULE

## Standard Product Specification

<b>PRODUCT NUMBER</b>	<b>LR2070</b>
-----------------------	---------------

Product Mgr	Quality Mgr	Electrical Eng	Document Control
Date:	Date:	Date:	Date:

- Approval for Specification only
- Approval for Specification and Sample

Sample no.:

Date:

ISIR no.:

Product No.	LR2070	REV. B
	LAF0821	REV. 1.0

Page	1 / 23
------	--------

# TABLE OF CONTENTS

<b>1</b>	<b>MAIN FEATURES.....</b>	<b>4</b>
<b>2</b>	<b>MECHANICAL SPECIFICATION.....</b>	<b>5</b>
2.1	MECHANICAL CHARACTERISTICS.....	5
2.2	LABELLING & MARKING.....	5
2.3	MECHANICAL DRAWING.....	6
<b>3</b>	<b>ELECTRICAL SPECIFICATION.....</b>	<b>7</b>
3.1	ABSOLUTE MAXIMUM RATINGS.....	7
3.2	ELECTRICAL CHARACTERISTICS.....	7
3.3	INTERFACE PIN ASSIGNMENT (EL).....	8
3.4	BLOCK DIAGRAM.....	9
3.5	POWER SUPPLY CIRCUIT.....	9
3.6	CHARACTER FONT.....	10
3.7	AC TIMING CHARACTERISTICS.....	11
<b>4</b>	<b>OPTICAL SPECIFICATION.....</b>	<b>13</b>
4.1	OPTICAL CHARACTERISTICS.....	13
<b>5</b>	<b>BACKLIGHT CHARACTERISTICS.....</b>	<b>15</b>
5.1	EL B/L OPERATING RANGE.....	15
<b>6</b>	<b>QUALITY ASSURANCE SPECIFICATION.....</b>	<b>15</b>
6.1	CONFORMITY.....	15
6.2	DELIVERY ASSURANCE.....	15
6.3	DEALING WITH CUSTOMER COMPLAINTS.....	20
<b>7</b>	<b>RELIABILITY TEST.....</b>	<b>21</b>
7.1	RELIABILITY (NORMAL TEMP. LCM).....	21
7.2	RELIABILITY (WIDE TEMP. LCM).....	21
7.3	LIFE TIME.....	21
<b>8</b>	<b>PART NUMBER DESCRIPTIONS FOR AVAILABLE OPTIONS.....</b>	<b>22</b>
<b>9</b>	<b>HANDLING PRECAUTIONS.....</b>	<b>23</b>

Product No.	LR2070	REV. B
	LAF0821	REV. 1.0

Page	2 / 23
------	--------

**REVISION RECORD**

<b>Rev.</b>	<b>Date</b>	<b>Page</b>	<b>Chapt.</b>	<b>Comment</b>	<b>ECN no.</b>
A	02/17/06	--	--	Initial DCA Release.	E2095
B	03/15/06	22	8	Change typo in part number description.	E3055

Product No.	LR2070	REV. B
	LAF0821	REV. 1.0

Page	3 / 23
------	--------

# 1 MAIN FEATURES

UNIT=MM

ITEM		CONTENTS
Display Format		2-line 8-character display
Colour		Monochrome
Overall Dimensions		58.0 (W) x 32.0 (H) x 9.5 (D) Max (EL version)
Viewing Area		35.0 (W) x 15.0 (H)
LCD Type		STN
Mode		Reflective \ Transflective - Positive
Viewing Angle		12:00
Duty Ratio		1/16
Driver IC		ST7066
Backlight Type \ Colour		EL \ Blue Green
DC/DC Converter		Built-In
Operating Temperature	Normal	0°C~+50°C
	Wide	-20°C~+70°C
Storage Temperature	Normal	0°C~+70°C
	Wide	-30°C~+80°C
RoHS Compliant		Yes

Product No.	LR2070	REV. B
	LAF0821	REV. 1.0

Page	4 / 23
------	--------

## 2 MECHANICAL SPECIFICATION

### 2.1 MECHANICAL CHARACTERISTICS

ITEM	CHARACTERISTIC	UNIT
Display Format	2-line 8-character display	
Overall Dimensions	58.0 (W) x 32.0 (H) x 9.5 (D) Max (EL version)	mm
Viewing Area	35.0 (W) x 15.0 (H)	mm
Active Area	27.76 (W) x 11.49 (H)	mm
Character Size	2.945 (W) x 5.545 (H)	mm
Character Pitch	3.545 (W) x 5.945 (H)	mm
Dot Size	0.545 (W) x 0.645 (H)	mm
Dot Pitch	0.6 (W) x 0.7 (H)	mm
IC Controller/Driver	ST7066	

### 2.2 LABELLING & MARKING

DENSITRON LR2070 TAIWAN YYMM
------------------------------------

Product No.	LR2070	REV. B
	LAF0821	REV. 1.0

Page	5 / 23
------	--------

## 2.3 MECHANICAL DRAWING

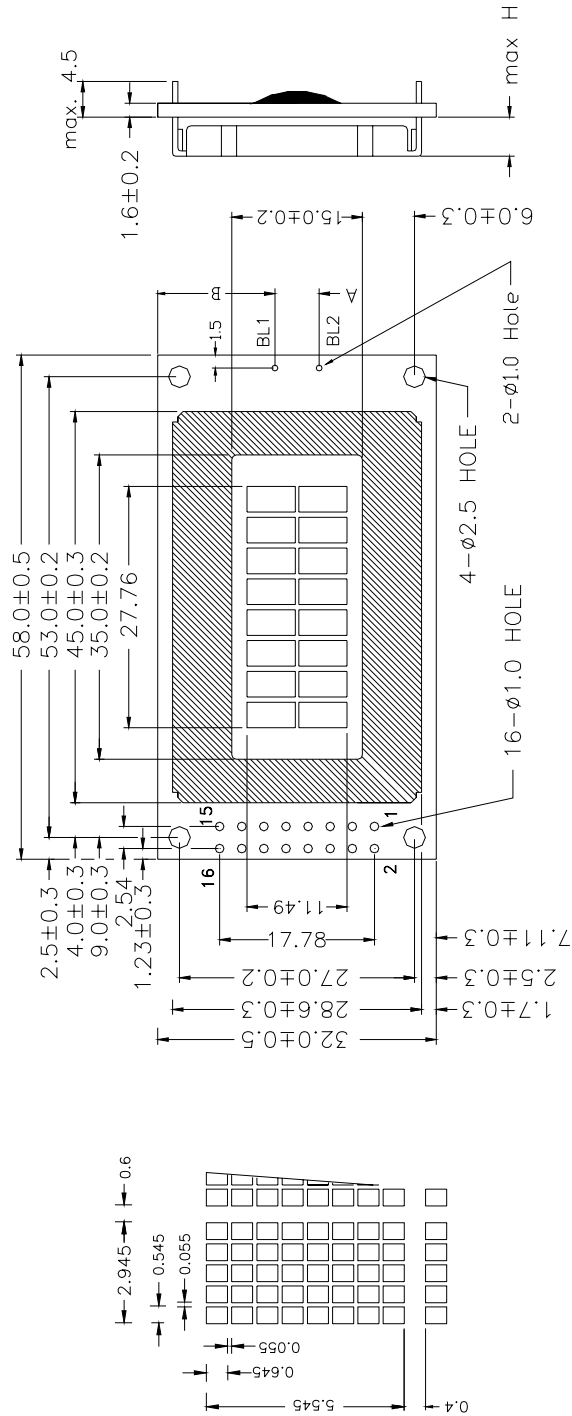

MODULE	H
EL	5.0

EL	A	B
	10.16	10.92

UNIT:mm

Product No.	LR2070	REV. B
	LAF0821	REV. 1.0

Page	6 / 23
------	--------

### 3 ELECTRICAL SPECIFICATION

#### 3.1 ABSOLUTE MAXIMUM RATINGS

VSS = 0 V, Ta = 25 °C

Item		Symbol	Min	Max	Unit	Note
Power Supply Voltage		V <sub>DD</sub>	0	7.0	V	
Power supply for LCD		V <sub>DD</sub> -V <sub>O</sub>	0	10.0	V	
Operating Temperature	Normal	Top	0	+50	°C	Note 1
	Wide		-20	+70		
Storage Temperature	Normal	T <sub>st</sub>	0	+70	°C	Note 2
	Wide		-30	+80		
Static Electricity		Be sure that you are grounded when handling displays.				

Note 1: Background colour changes slightly depending on ambient temperature. This phenomenon is reversible. Ta ≤ 70 °C: 75% RH max

Note 2: Ta ≤ 80 °C: 75% RH max

#### 3.2 ELECTRICAL CHARACTERISTICS

VSS = 0 V, Ta = 25 °C

Item	Symbol	Condition	Min	Typ	Max	Unit
Power Supply for Logic	V <sub>DD</sub> -V <sub>SS</sub>	Ta = 25°C	4.75	--	5.25	V
Input Voltage	V <sub>IHC</sub>	Ta = 25°C	2.2	--	V <sub>DD</sub>	V
	V <sub>ILC</sub>	Ta = 25°C	0	--	0.6	V
LCD Module Driving Voltage	V <sub>DD</sub> -V <sub>O</sub>	Ta = 25°C	0	--	10.0	V
Current Consumption	* I <sub>DD</sub>	V <sub>DD</sub> -V <sub>SS</sub> = 5V	--	2.2	--	mA

\* I<sub>DD</sub> measurement condition is for all pattern ON

Product No.	LR2070	REV. B
	LAF0821	REV. 1.0

Page	7 / 23
------	--------

### 3.3 INTERFACE PIN ASSIGNMENT (EL)

Pin No.	Function	Level	Description
1	VSS	–	Ground (0V)
2	VDD	–	Logic Supply Voltage (+5V)
3	Vo	–	Voltage Level for LCD Control Adjustment
4	RS	I	Register Select 0: Instruction Register 1: Data Register
5	R/W	I	Read / Write 0: Data Write (Module ← MPU) 1: Data Read (Module → MPU)
6	E	I	Enable Signal Active High (H → L)
7 ~ 14	DB0 ~ 7	I/O	Bi-directional data bus line 0 ~ 7
15 ~ 16	NC		No connection
BL1	EL		EL B/L
BL2	EL		EL B/L

Product No.	LR2070	REV. B
	LAF0821	REV. 1.0

Page	8 / 23
------	--------



### 3.4 BLOCK DIAGRAM

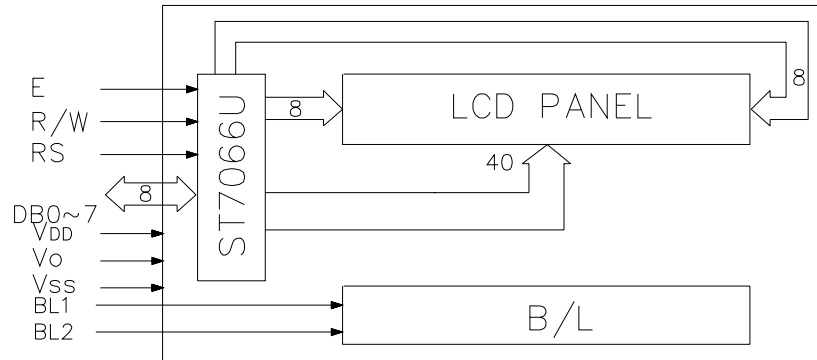

### 3.5 POWER SUPPLY CIRCUIT

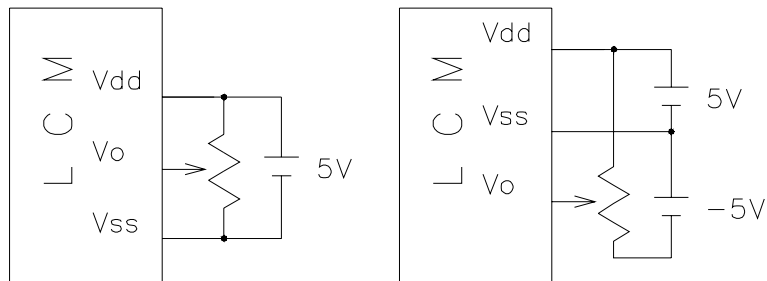

Normal temp.

Wide temp.

RECOMMENDED Vr: 10K ohm ~ 20K ohm

Product No.	LR2070	REV. B
	LAF0821	REV. 1.0

Page	9 / 23
------	--------

### 3.6 CHARACTER FONT

NO.7066-0A

b7-b4 b3-b0	0000	0001	0010	0011	0100	0101	0110	0111	1000	1001	1010	1011	1100	1101	1110	1111	
0000	CG RAM (1)			0	1	A	P	\	P				-	9	E	o	p
0001	(2)		!	1	A	Q	a	q			.	7	7	4	ä	q	
0010	(3)		"	2	B	R	b	r			「	イ	ウ	×	β	θ	
0011	(4)		#	3	C	S	c	s			」	ウ	テ	ε	ε	ε	ε
0100	(5)		\$	4	D	T	d	t			、	イ	ト	ト	μ	Ω	
0101	(6)		%	5	E	U	e	u			.	オ	ナ	1	ε	ü	
0110	(7)		&	6	F	V	f	v			ヲ	カ	ニ	ヨ	ρ	Σ	
0111	(8)		'	7	G	W	g	w			ア	キ	ヌ	ウ	g	π	
1000	(1)		(	8	H	X	h	x			イ	ウ	※	リ	フ	Σ	
1001	(2)		)	9	I	Y	i	y			ウ	テ	リ	ル	リ	γ	
1010	(3)		*	:	J	Z	j	z			エ	コ	ハ	レ	j	キ	
1011	(4)		+	:	K	L	k	l			*	ウ	レ	ロ	*	ル	
1100	(5)		,	<	L	¥	l	l			ウ	シ	フ	フ	φ	ル	
1101	(6)		-	=	M	I	m	>			ユ	ズ	ハ	ソ	ト	÷	
1110	(7)		.	>	N	^	n	→			ヨ	セ	ホ	ハ	ル		
1111	(8)		/	?	O	_	o	←			ウ	ソ	マ	マ	ö		

Product No.	LR2070	REV. B
	LAF0821	REV. 1.0

Page	10 / 23
------	---------

### 3.7 AC TIMING CHARACTERISTICS

#### ST7066U

#### ■ AC Characteristics

(TA = 25°C, VCC = 5V)

Symbol	Characteristics	Test Condition	Min.	Typ.	Max.	Unit
<i>Internal Clock Operation</i>						
f <sub>OSC</sub>	OSC Frequency	R = 91KΩ	190	270	360	KHz
<i>External Clock Operation</i>						
f <sub>EX</sub>	External Frequency	-	125	270	410	KHz
	Duty Cycle	-	45	50	55	%
T <sub>R</sub> , T <sub>F</sub>	Rise/Fall Time	-	-	-	0.2	μs
<i>Write Mode (Writing data from MPU to ST7066U)</i>						
T <sub>C</sub>	Enable Cycle Time	Pin E	1200	-	-	ns
T <sub>PW</sub>	Enable Pulse Width	Pin E	140	-	-	ns
T <sub>R</sub> , T <sub>F</sub>	Enable Rise/Fall Time	Pin E	-	-	25	ns
T <sub>AS</sub>	Address Setup Time	Pins: RS, RW, E	0	-	-	ns
T <sub>AH</sub>	Address Hold Time	Pins: RS, RW, E	10	-	-	ns
T <sub>DSW</sub>	Data Setup Time	Pins: DB0 - DB7	40	-	-	ns
T <sub>H</sub>	Data Hold Time	Pins: DB0 - DB7	10	-	-	ns
<i>Read Mode (Reading Data from ST7066U to MPU)</i>						
T <sub>C</sub>	Enable Cycle Time	Pin E	1200	-	-	ns
T <sub>PW</sub>	Enable Pulse Width	Pin E	140	-	-	ns
T <sub>R</sub> , T <sub>F</sub>	Enable Rise/Fall Time	Pin E	-	-	25	ns
T <sub>AS</sub>	Address Setup Time	Pins: RS, RW, E	0	-	-	ns
T <sub>AH</sub>	Address Hold Time	Pins: RS, RW, E	10	-	-	ns
T <sub>DDR</sub>	Data Setup Time	Pins: DB0 - DB7	-	-	100	ns
T <sub>H</sub>	Data Hold Time	Pins: DB0 - DB7	10	-	-	ns
<i>Interface Mode with LCD Driver(ST7065)</i>						
T <sub>CWH</sub>	Clock Pulse with High	Pins: CL1, CL2	800	-	-	ns
T <sub>CWL</sub>	Clock Pulse with Low	Pins: CL1, CL2	800	-	-	ns
T <sub>CST</sub>	Clock Setup Time	Pins: CL1, CL2	500	-	-	ns
T <sub>SU</sub>	Data Setup Time	Pin: D	300	-	-	ns
T <sub>OH</sub>	Data Hold Time	Pin: D	300	-	-	ns
T <sub>DM</sub>	M Delay Time	Pin: M	0	-	2000	ns

Product No.	LR2070	REV. B
	LAF0821	REV. 1.0

Page	11 / 23
------	---------

ST7066U

■ Timing Characteristics

- Writing data from MPU to ST7066U

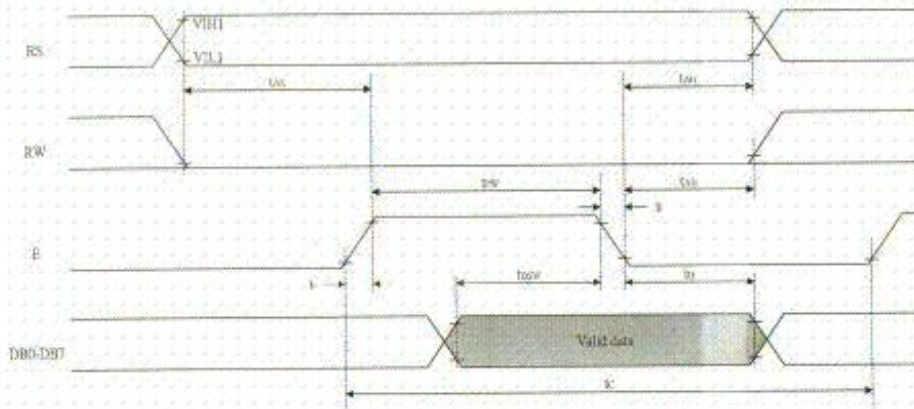

- Reading data from ST7066U to MPU

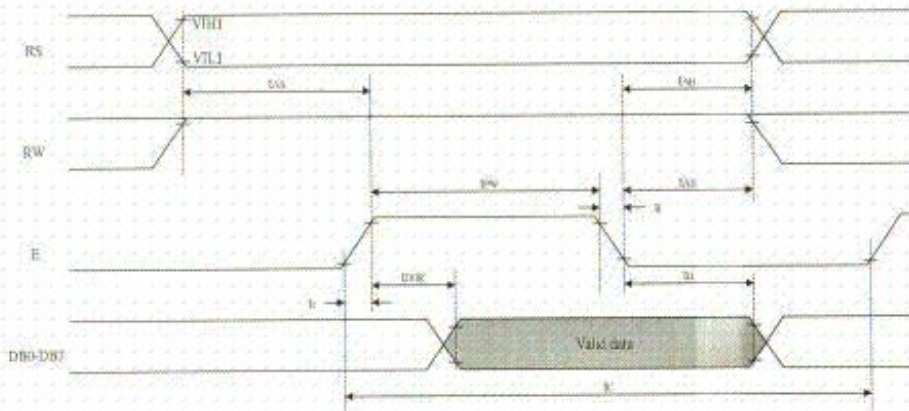

Product No.	LR2070	REV. B
	LAF0821	REV. 1.0

Page	12 / 23
------	---------

## 4 OPTICAL SPECIFICATION

### 4.1 OPTICAL CHARACTERISTICS

Ta = 25 °C

Item	Symbol	Condition	Min	Typ	Max	Unit	Note
Viewing Angle	θ1	CR≥2	--	35	--	deg	1
	θ2	CR≥2	--	10	--	deg	1
	θ3	CR≥2	--	35	--	deg	2
	θ4	CR≥2	--	35	--	deg	2
Contrast Ratio	CR	Ta = 25 °C	2	5	--	-	3
Response Time	Tr	Ta = 25 °C	--	155	250	ms	4
	Tf	Ta = 25 °C	--	66	150		
Driving Method	Duty	1/16					
	Bias	1/5					
LCD Type	STN						
Mode	Reflective - Transflective - Positive						

Product No.	LR2070	REV. B
	LAF0821	REV. 1.0

Page	13 / 23
------	---------

Note 1: definition of viewing angle  $\theta_1$  &  $\theta_2$

Note 2: definition of viewing angle  $\theta_3$  &  $\theta_4$

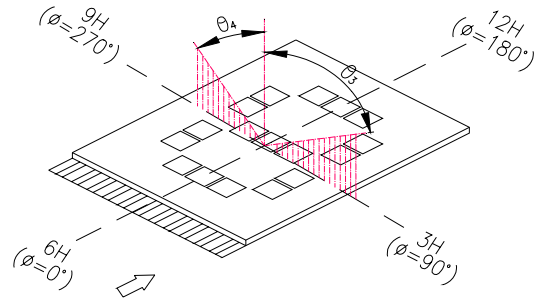
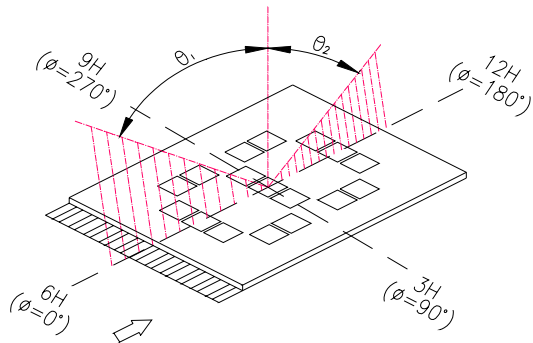

Note 3: definition of contrast ratio (CR)

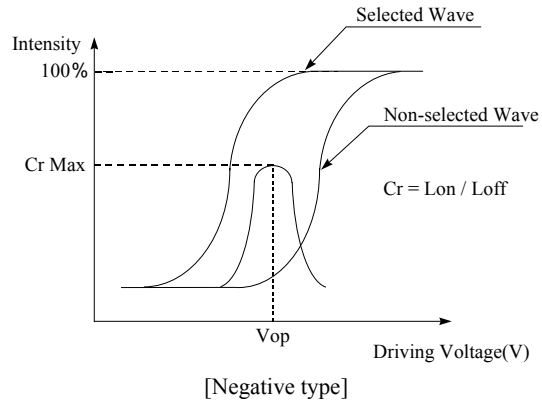
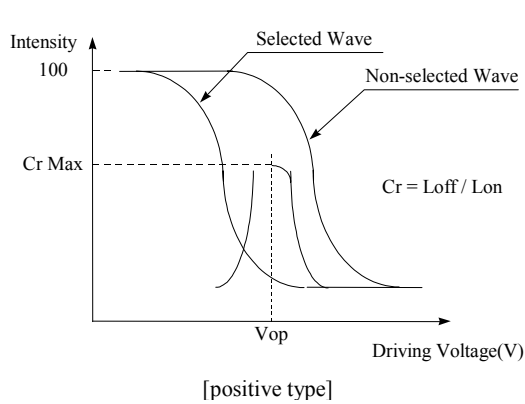

Note 4: definition of response time

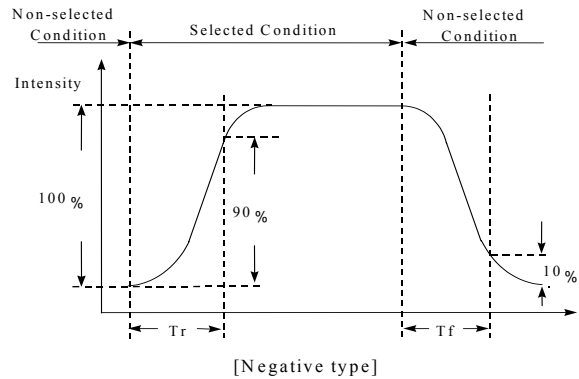
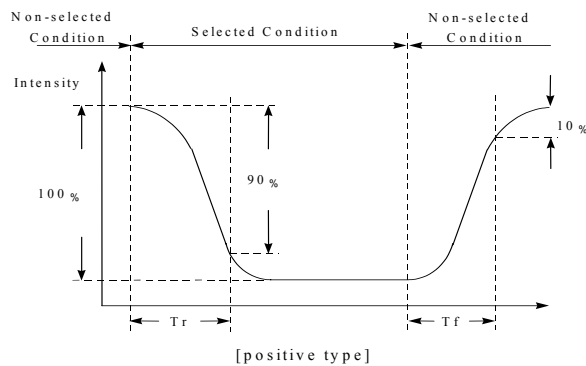

Product No.	LR2070	REV. B
	LAF0821	REV. 1.0

Page	14 / 23
------	---------

## 5 BACKLIGHT CHARACTERISTICS

### 5.1 EL B/L operating range

Item	Conditions	Standard			Unit
		Min.	Typ.	Max.	
Input voltage	Ta = 25 C (400 ~ 800 Hz)	---	100	---	Vrms
Current consumption	Ta = 25 C		1.25		mA
Average brightness (B/L only) (Ta=25C, I=3.5 mA)	Test when connecting after 3 min. Ta=25C (max. contrast)	---	50	---	cd/m2 (Note 2)
Lamp life	Ta = 25 C , I = 3.5 mA Humidity : 30%RH ~ 85%RH	---	3,000	---	Hrs (Note 4)
Operating Temp.	Humidity : 30%RH ~ 85%RH	-20	---	70	C
Storage Temp.	Humidity : 30%RH ~ 85%RH	-30	---	80	C

## 6 QUALITY ASSURANCE SPECIFICATION

### 6.1 CONFORMITY

The performance, function and reliability of the shipped products conform to the Product Specification.

### 6.2 DELIVERY ASSURANCE

#### 6.2.1 Delivery inspection standards

- MIL-STD-105E, general inspection level II, single sampling level;
- IPC-AA610 rev. C, class 2 electronic assemblies standard

The quality assurance levels are shown below:

Class	AQL (%)
Critical defect	0.5%
Major defect	1.0%
Minor defect	1.5%
TOTAL	2.0%

Product No.	LR2070	REV. B
	LAF0821	REV. 1.0

Page	15 / 23
------	---------

### 6.2.2 Zone definition

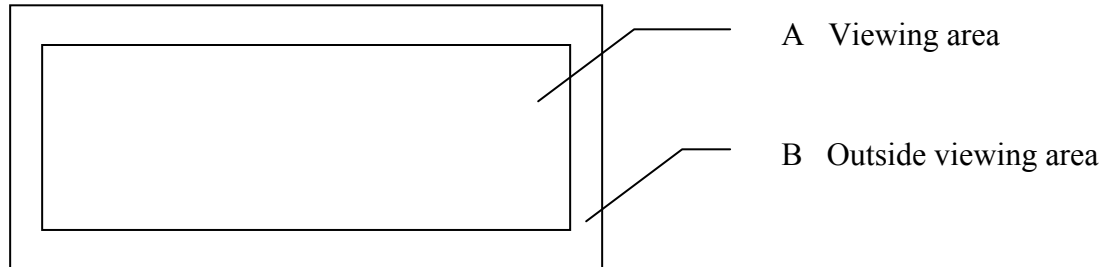

### 6.2.3 Visual inspection

- Inspect under 2x20W or 40W fluorescent lamp (approximately 3000 lux) leaving 25 to 30 cm between the module and the lamp and 30 cm between the module and the eye (measuring position).
- Appearance is inspected at the best contrast voltage (best contrast is adjusted considering clearness and crosstalk on screen).
- Inspect the module at 45° right and left, top and bottom.
- Use the optimum viewing angle during the contrast inspection.

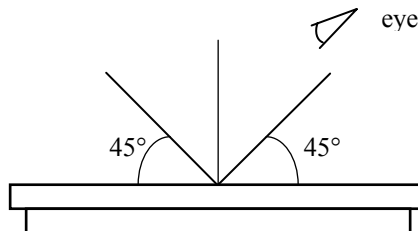

Product No.	LR2070	REV. B
	LAF0821	REV. 1.0

Page	16 / 23
------	---------



### 6.2.3.1 Standard of appearance inspection

Units: mm

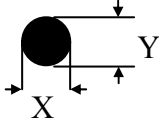
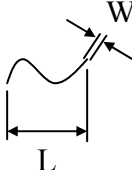
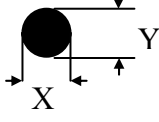
Class	Item	Criteria																																			
Minor	Packing & Label	Outside & inside package																																			
Critical		Presence of product no., lot no., quantity																																			
		Product must not be mixed with others and quantity must not be different from that indicated on the label																																			
Major	Dimension	Product dimensions must be according to specification and drawing																																			
Major	Electrical	Product electrical characteristics must be according to specification																																			
Critical	LCD Display	Missing lines or wrong patterns on LCD display are not allowed																																			
Minor	Black spot, white spot, dust	<p>Round type: as per following drawing  <math>\varnothing = (X+Y)/2</math></p>  <table border="1" style="margin-left: auto; margin-right: auto;"> <thead> <tr> <th colspan="3">Acceptable quantity</th> </tr> <tr> <th>Size</th> <th>Zone A</th> <th>Zone B</th> </tr> </thead> <tbody> <tr> <td><math>\varnothing &lt; 0.1</math></td> <td>Any number</td> <td rowspan="4">Any number</td> </tr> <tr> <td><math>0.1 &lt; \varnothing &lt; 0.2</math></td> <td>2</td> </tr> <tr> <td><math>0.2 &lt; \varnothing &lt; 0.25</math></td> <td>1</td> </tr> <tr> <td><math>0.25 &lt; \varnothing</math></td> <td>0</td> </tr> </tbody> </table> <p>Line type: as per following drawing</p>  <table border="1" style="margin-left: auto; margin-right: auto;"> <thead> <tr> <th colspan="4">Acceptable quantity</th> </tr> <tr> <th>Length</th> <th>Width</th> <th>Zone A</th> <th>Zone B</th> </tr> </thead> <tbody> <tr> <td>--</td> <td><math>W \leq 0.02</math></td> <td>Any number</td> <td rowspan="4">Any number</td> </tr> <tr> <td><math>L \leq 3.0</math></td> <td><math>0.02 &lt; W \leq 0.03</math></td> <td>2</td> </tr> <tr> <td><math>L \leq 2.5</math></td> <td><math>0.03 &lt; W \leq 0.05</math></td> <td rowspan="2">As round type</td> </tr> <tr> <td>--</td> <td><math>0.05 &lt; W</math></td> </tr> </tbody> </table> <p style="text-align: center;">Total acceptable quantity: 3</p>	Acceptable quantity			Size	Zone A	Zone B	$\varnothing < 0.1$	Any number	Any number	$0.1 < \varnothing < 0.2$	2	$0.2 < \varnothing < 0.25$	1	$0.25 < \varnothing$	0	Acceptable quantity				Length	Width	Zone A	Zone B	--	$W \leq 0.02$	Any number	Any number	$L \leq 3.0$	$0.02 < W \leq 0.03$	2	$L \leq 2.5$	$0.03 < W \leq 0.05$	As round type	--	$0.05 < W$
Acceptable quantity																																					
Size	Zone A	Zone B																																			
$\varnothing < 0.1$	Any number	Any number																																			
$0.1 < \varnothing < 0.2$	2																																				
$0.2 < \varnothing < 0.25$	1																																				
$0.25 < \varnothing$	0																																				
Acceptable quantity																																					
Length	Width	Zone A	Zone B																																		
--	$W \leq 0.02$	Any number	Any number																																		
$L \leq 3.0$	$0.02 < W \leq 0.03$	2																																			
$L \leq 2.5$	$0.03 < W \leq 0.05$	As round type																																			
--	$0.05 < W$																																				
Minor	Polariser scratch	Scratch on protective film is permitted Scratch on polariser: same as No. 1																																			
Minor	Polariser bubble	<p><math>\varnothing = (X+Y)/2</math></p>  <table border="1" style="margin-left: auto; margin-right: auto;"> <thead> <tr> <th colspan="3">Acceptable quantity</th> </tr> <tr> <th>Size</th> <th>Zone A</th> <th>Zone B</th> </tr> </thead> <tbody> <tr> <td><math>\varnothing &lt; 0.2</math></td> <td>Any number</td> <td rowspan="4">Any number</td> </tr> <tr> <td><math>0.2 &lt; \varnothing &lt; 0.5</math></td> <td>2</td> </tr> <tr> <td><math>0.5 &lt; \varnothing &lt; 1.0</math></td> <td>1</td> </tr> <tr> <td><math>1.0 &lt; \varnothing</math></td> <td>0</td> </tr> </tbody> </table> <p style="text-align: center;">Total acceptable quantity: 3</p>	Acceptable quantity			Size	Zone A	Zone B	$\varnothing < 0.2$	Any number	Any number	$0.2 < \varnothing < 0.5$	2	$0.5 < \varnothing < 1.0$	1	$1.0 < \varnothing$	0																				
Acceptable quantity																																					
Size	Zone A	Zone B																																			
$\varnothing < 0.2$	Any number	Any number																																			
$0.2 < \varnothing < 0.5$	2																																				
$0.5 < \varnothing < 1.0$	1																																				
$1.0 < \varnothing$	0																																				

Product No.	LR2070	REV. B
	LAF0821	REV. 1.0

Page	17 / 23
------	---------

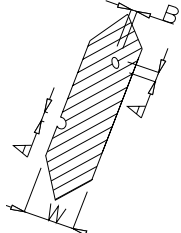
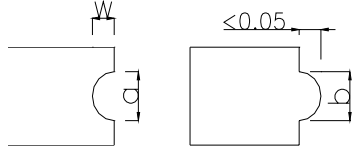
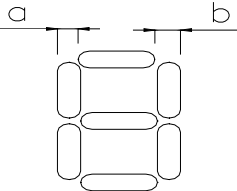
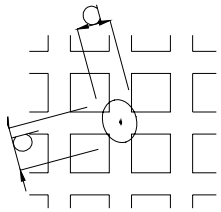
Class	Item	Criteria																												
Minor	Segment deformation	<p>1.a. Pin hole on segmented display  W: segment width  <math>\varnothing = (A+B)/2</math></p>  <table border="1" style="margin-left: auto; margin-right: auto;"> <thead> <tr> <th colspan="2">Acceptable quantity</th> </tr> <tr> <th>Width</th> <th><math>\varnothing</math></th> </tr> </thead> <tbody> <tr> <td><math>W \leq 0.4</math></td> <td><math>\varnothing \leq 0.2</math> and <math>\varnothing \leq 1/2W</math></td> </tr> <tr> <td><math>W &gt; 0.4</math></td> <td><math>\varnothing \leq 0.25</math> and <math>\varnothing \leq 1/3W</math></td> </tr> </tbody> </table> <p>Total acceptable quantity: 1 defect per segment  Pin holes with <math>\varnothing</math> under 0.10 mm are acceptable</p>	Acceptable quantity		Width	$\varnothing$	$W \leq 0.4$	$\varnothing \leq 0.2$ and $\varnothing \leq 1/2W$	$W > 0.4$	$\varnothing \leq 0.25$ and $\varnothing \leq 1/3W$																				
Acceptable quantity																														
Width	$\varnothing$																													
$W \leq 0.4$	$\varnothing \leq 0.2$ and $\varnothing \leq 1/2W$																													
$W > 0.4$	$\varnothing \leq 0.25$ and $\varnothing \leq 1/3W$																													
Minor	Segment deformation	<p>1b. Pin hole on dot matrix display</p>  <table border="1" style="margin-left: auto; margin-right: auto;"> <thead> <tr> <th colspan="2">Acceptable quantity</th> </tr> <tr> <th>Size</th> <th></th> </tr> </thead> <tbody> <tr> <td><math>a, b &lt; 0.1</math></td> <td>Any number</td> </tr> <tr> <td><math>(a+b)/2 \leq 0.1</math></td> <td>Any number</td> </tr> <tr> <td><math>0.5 &lt; \varnothing &lt; 1.0</math></td> <td>3</td> </tr> </tbody> </table> <p>Total acceptable quantity: 7</p> <p>2. Segments / dots with different width</p>  <table border="1" style="margin-left: auto; margin-right: auto;"> <thead> <tr> <th colspan="2">Acceptable</th> </tr> </thead> <tbody> <tr> <td><math>a \geq b</math></td> <td><math>a/b \leq 4/3</math></td> </tr> <tr> <td><math>a &lt; b</math></td> <td><math>a/b &gt; 4/3</math></td> </tr> </tbody> </table> <p>3. Alignment layer defect  <math>\varnothing = (a+b)/2</math></p>  <table border="1" style="margin-left: auto; margin-right: auto;"> <thead> <tr> <th colspan="2">Acceptable quantity</th> </tr> <tr> <th>Size</th> <th></th> </tr> </thead> <tbody> <tr> <td><math>\varnothing \leq 0.4</math></td> <td>Any number</td> </tr> <tr> <td><math>0.4 &lt; \varnothing \leq 1.0</math></td> <td>5</td> </tr> <tr> <td><math>1.0 &lt; \varnothing \leq 1.5</math></td> <td>3</td> </tr> <tr> <td><math>1.5 &lt; \varnothing \leq 2.0</math></td> <td>2</td> </tr> </tbody> </table> <p>Total acceptable quantity: 7</p>	Acceptable quantity		Size		$a, b < 0.1$	Any number	$(a+b)/2 \leq 0.1$	Any number	$0.5 < \varnothing < 1.0$	3	Acceptable		$a \geq b$	$a/b \leq 4/3$	$a < b$	$a/b > 4/3$	Acceptable quantity		Size		$\varnothing \leq 0.4$	Any number	$0.4 < \varnothing \leq 1.0$	5	$1.0 < \varnothing \leq 1.5$	3	$1.5 < \varnothing \leq 2.0$	2
Acceptable quantity																														
Size																														
$a, b < 0.1$	Any number																													
$(a+b)/2 \leq 0.1$	Any number																													
$0.5 < \varnothing < 1.0$	3																													
Acceptable																														
$a \geq b$	$a/b \leq 4/3$																													
$a < b$	$a/b > 4/3$																													
Acceptable quantity																														
Size																														
$\varnothing \leq 0.4$	Any number																													
$0.4 < \varnothing \leq 1.0$	5																													
$1.0 < \varnothing \leq 1.5$	3																													
$1.5 < \varnothing \leq 2.0$	2																													
Minor	Colour uniformity	Level of sample for approval set as limit sample																												
Critical	Backlight	The backlight colour should correspond to the product specification																												
Critical		Flashing and or unlit backlight is not allowed																												
Minor		Dust larger than 0.25 mm is not allowed																												
Major	COB	Exposed wire bond pad is not allowed																												
Major		Insufficient covering with resin is not allowed (wire bond line exposed)																												
Minor		Dust or bubble on the resin are not allowed																												

Product No.	LR2070	REV. B
	LAF0821	REV. 1.0

Page	18 / 23
------	---------

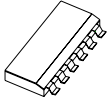
Class	Item	Criteria													
Major		No unmelted solder paste should be present on PCB													
Critical		Cold solder joints, missing solder connections, or oxidation are not allowed													
Minor		No residue or solder balls on PCB are allowed													
Critical		Short circuits on components are not allowed													
Minor	Tray particles	<table border="1"> <thead> <tr> <th></th> <th>Size</th> <th>Quantity</th> </tr> </thead> <tbody> <tr> <td rowspan="2">On tray</td> <td><math>\varnothing &lt; 0.2</math></td> <td>Any number</td> </tr> <tr> <td><math>\varnothing &gt; 0.25</math></td> <td>4</td> </tr> <tr> <td rowspan="2">On display</td> <td><math>\varnothing \geq 0.25</math></td> <td>2</td> </tr> <tr> <td><math>L = 3</math></td> <td>1</td> </tr> </tbody> </table>		Size	Quantity	On tray	$\varnothing < 0.2$	Any number	$\varnothing > 0.25$	4	On display	$\varnothing \geq 0.25$	2	$L = 3$	1
	Size	Quantity													
On tray	$\varnothing < 0.2$	Any number													
	$\varnothing > 0.25$	4													
On display	$\varnothing \geq 0.25$	2													
	$L = 3$	1													

Product No.	LR2070	REV. B
	LAF0821	REV. 1.0

Page	19 / 23
------	---------

## **6.3 DEALING WITH CUSTOMER COMPLAINTS**

---

### **6.3.1 Non-conforming analysis**

Purchaser should supply Densitron with detailed data of non-conforming sample.

After accepting it, Densitron should complete the analysis in two weeks from receiving the sample.

If the analysis cannot be completed on time, Densitron must inform the purchaser.

### **6.3.2 Handling of non-conforming displays**

If any non-conforming displays are found during customer acceptance inspection which Densitron is clearly responsible for, return them to Densitron.

Both Densitron and customer should analyse the reason and discuss the handling of non-conforming displays when the reason is not clear.

Equally, both sides should discuss and come to agreement for issues pertaining to modification of Densitron quality assurance standard.

Product No.	LR2070	REV. B
	LAF0821	REV. 1.0

Page	20 / 23
------	---------

## 7 RELIABILITY TEST

### 7.1 Reliability (Normal temp. LCM)

Test Item	Test Condition	Evaluation and assessment
High Temperature Operation	50°C ±2°C, 240 hours	No abnormalities in function* and appearance
Low Temperature Operation	0°C ±2°C, 240 hours	No abnormalities in function* and appearance
Thermal Shock Storage (Non operation)	-20°C (30 min)->25°C (5 min)->70°C (30 min)->25°C (5 min) 5 cycles.	No abnormalities in function* and appearance
Vibration (Non operation)	10 Hz~55 Hz 0.3mm / 1 Octave 55 Hz~500 Hz 3g / 1 Octave 20 cycles per axis	No abnormalities in function* and appearance

### 7.2 Reliability (Wide temp. LCM)

Test Item	Test Condition	Evaluation and assessment
High Temperature Operation	70°C ±2°C, 240 hours	No abnormalities in function* and appearance
Low Temperature Operation	-20°C ±2°C, 240 hours	No abnormalities in function* and appearance
Thermal Shock Storage (Non operation)	-30°C (30 min)->25°C (5 min)->80°C (30 min)->25°C (5 min) 5 cycles.	No abnormalities in function* and appearance
Vibration (Non operation)	10 Hz~55 Hz 0.3mm / 1 Octave 55 Hz~500 Hz 3g / 1 Octave 20 cycles per axis	No abnormalities in function* and appearance

### 7.3 LIFE TIME

Item	Description
1	Function, performance, appearance, etc. shall be free from remarkable deterioration within 50,000 hours under ordinary operating and storage conditions of room temperature (25±10 °C), normal humidity (45±20% RH), and in area not exposed to direct sunlight.

Product No.	LR2070	REV. B
	LAF0821	REV. 1.0

Page	21 / 23
------	---------

**8 PART NUMBER DESCRIPTIONS FOR AVAILABLE OPTIONS**

**LR2070①②2C08③④⑤**

- ① **Polarizer Type**  
 A= Reflective: light background with no backlight.  
 B = Transflective: light background with blue-green EL backlight.
- ② **Not applicable - LEAVE BLANK**
- ③ **Fluid Type and Power Supply**  
 S = STN with +5VDC operation  
 H = Wide temperature range, negative supply voltage required.
- ④ **Fluid Type Viewing Direction**  
 N = STN
- ⑤ **Background Color for STN Temperature Range**  
 G = Gray background

Product No.	LR2070	REV. B
	LAF0821	REV. 1.0

Page	22 / 23
------	---------

## 9 HANDLING PRECAUTIONS

### *Safety*

If the LCD panel breaks, be careful not to get the liquid crystal fluid in your mouth or in your eyes.  
If the liquid crystal touches your skin or clothes, wash it off immediately using soap and plenty of water.

### *Mounting and Design*

Place a transparent plate (e.g. acrylic, polycarbonate or glass) on the display surface to protect the display from external pressure. Leave a small gap between the transparent plate and the display surface. When assembling with a zebra connector, clean the surface of the pads with alcohol and keep the surrounding air very clean. Design the system so that no input signal is given unless the power supply voltage is applied.

### *Caution during LCD cleaning*

Lightly wipe the display surface with a soft cloth soaked with Isopropyl alcohol, Ethyl alcohol or Trichlorotrifluoroethane. Do not wipe the display surface with dry or hard materials that will damage the polariser surface. Do not use aromatic solvents (toluene and xylene), or ketonic solvents (ketone and acetone).

### *Caution against static charge*

As the display uses C-MOS LSI drivers, connect any unused input terminal to VDD or VSS. Do not input any signals before power is turned on.  
Also, ground your body, work/assembly table and assembly equipment to protect against static electricity.

### *Packaging*

Displays use LCD elements, and must be treated as such. Avoid strong shock and drop from a height. To prevent displays from degradation, do not operate or store them exposed directly to sunshine or high temperature/humidity.

### *Caution during operation*

It is indispensable to drive the display within the specified voltage limit since excessive voltage shortens its life. Direct current causes an electrochemical reaction with remarkable deterioration of the display quality. Give careful consideration to prevent direct current during ON/OFF timing and during operation. Response time is extremely delayed at temperatures lower than the operating temperature range while, at high temperatures, displays become dark. However, this phenomenon is reversible and does not mean a malfunction or a display that has been permanently damaged. If the display area is pushed on hard during operation, some graphics will be abnormally displayed but returns to a normal condition after turning off the display once. Even a small amount of condensation on the contact pads (terminals) can cause an electro-chemical reaction which causes missing rows and columns. Give careful attention to avoid condensation.

### *Storage*

Store the display in a dark place where the temperature is  $25^{\circ}\text{C} \pm 10^{\circ}\text{C}$  and the humidity below 50%RH. Store the display in a clean environment, free from dust, organic solvents and corrosive gases. Do not crash, shake or jolt the display (including accessories).

Product No.	LR2070	REV. B
	LAF0821	REV. 1.0

Page	23 / 23
------	---------