

The information disclosed herein was originated by and is the property of Densitron International. Densitron International reserves all patent, proprietary, design, use, sales, manufacturing and reproduction rights thereto.

REVISIONS			
REV.	DESCRIPTION	DATE	APPROVED
A	RELEASED ON ECN #E1564	10/09/03	MA

- 1. Specification subject to change without notice.**
- 2. All dimensions and specifications apply to standard modules. This information may vary for modules with optional features.**
- 3. All dimensions are in millimeters.**
- 4. Precautions: These precautions apply equally to modules from all makers, not just Densitron. Violation of these guidelines may void the warranty and can cause problems ranging from erratic operation to catastrophic display failure.**

Handling precautions:

- ◆ This device is susceptible to Electro-Static Discharge (ESD) damage. Observe Anti-Static precautions.

Power supply precautions:

- ◆ Identify and, at all times, observe absolute maximum ratings for both logic and LC drivers. Note that there is some variance between models.
- ◆ Prevent the application of reverse polarity to VDD and VSS, however briefly.
- ◆ Use a clean power source free from transients. Power up conditions are occasionally "jolting" and may exceed the maximum ratings of the module.
- ◆ The +5V power of the module should also supply the power to all devices which may access the display. Don't allow the data bus to be driven when the logic supply to the module is turned off.
- ◆ DO NOT install a capacitor between the Vo (contrast) pin and ground. VDD must, at all times, exceed the Vo voltage level. The capacitor combines with the contrast potentiometer to form an R-C network which "holds-up" Vo, at power-down, possibly damaging the module.

Operating precautions:

- ◆ DO NOT plug or unplug the module when the system is powered up.
- ◆ Minimize the cable length between the module and host MPU. (Recommended max. length 30 cm).
- ◆ For models with EL backlights, do not disable the backlight by interrupting the HV line. Unloaded inverters produce voltage extremes which may arc within a cable or at the display.
- ◆ Operate the module within the limits of the modules temperature specifications.

Mechanical / Environmental precautions:

- ◆ Improper soldering is the major cause of module difficulty. Use of flux cleaner is not recommended as they may seep under the elastomeric connection and cause display failure. Densitron recommends the use of Kester "245" no-clean solder.
- ◆ Mount the module so that it is free from torque and mechanical stress.
- ◆ Surface of LCD panel should not be touched or scratched. The display front surface is an easily scratched, plastic polarizer. Avoid contact and clean only when necessary with soft, absorbent cotton dampened with petroleum benzene.
- ◆ ALWAYS employ anti-static procedure while handling the module.
- ◆ Prevent moisture build-up upon the module and observe the environmental constraints for storage temperature and humidity.
- ◆ DO NOT store in direct sunlight.
- ◆ If leakage of the liquid crystal material should occur, avoid contact with this material, particularly ingestion. If the body or clothing becomes contaminated by the liquid crystal material, wash thoroughly with water and soap.

Notes: (unless otherwise specified)

Unless otherwise specified: Dimensions are mm Tolerances are: X = ± 3 .X = ± 0.5 .XX = ± 0.05 Cage Code #OWS52	APPROVALS	DATE	DENSITRON TECHNOLOGIES PLC	
	DRAWN			
	CHECKED		TITLE	LCD MODULE COB 2 LINE X 24 CHARACTERS
	ISSUED		DWG. NO.	LC4427

1.0 DESCRIPTION

Dot matrix display module consisting of a Liquid Crystal Display, CMOS driver and controller LSI, printed circuit board, metal support frame, also Array LED backlight.

Available LC fluids types are: STN-H (extended temperature range STN).

2.0 MECHANICAL CHARACTERISTICS

Item	Specifications	Unit
Package Dimensions	118.0 (W) x 36.0 (H) x 14.0 max (D)	mm
Display format	2 line x 24 characters	-
Character font format	5 (W) x 7 (H) with attached cursor	dots
Driving method	1/16	duty
Dot size	0.6 (W) x 0.65 (H)	mm
Dot pitch	0.65 (W) x 0.70(H)	mm
Character Size	3.2 (W) x 5.55 (H)	mm
Active display area	88.3 (W) x 11.5 (H)	mm
Viewing area	93.5 (W) x 15.8 (H)	mm
Weight		g

Notes:W-Width;H-Height;D-Depth.

3.0 ABSOLUTE MAXIMUM RATINGS

V_{SS}=0V;T_a=25°C

Item	Symbol	STN-H		Unit
		Min.	Max.	
Logic supply voltage	V _{DD} -V _{SS}	0	7	V
LC driver supply voltage	V _{DD} -V _O	0	10	V
Operating temperature	T _{OP}	-20	+70 (Note 3)	°C
Storage temperature (Note 1)	T _{ST}	-30	+80	
Humidity: Operating (@40°C)	-	-	85%	RH (Note 2)
Non-operating (@40°C)	-	-	95%	RH (Note 2)

Notes: 1: Tested to 100 hrs.
2: Refers to non-condensing conditions.
3: It is not recommended to operate EL lamp above 50°C.

4.0 ELECTRICAL CHARACTERISTICS

V_{DD}=5±0.25V;T_a=25°C

Item	Symbol	Test Condition	Min.	Typ.	Max.	Unit
Input "High" voltage	V _{IH}	-	2.2	-	V _{DD}	V
Input "Low" voltage	V _{IL}	-	-	-	0.6	V
Output "High" voltage	V _{OH}	I _{OH} =0.205mA	2.4	-	-	V
Output "Low" voltage	V _{OL}	I _{OL} =1.2mA	-	-	0.4	V
Power supply current	I _{DD}	V _{DD} =5.0V	-	3	-	mA

5.0 RECOMMENDED LC DRIVE VOLTAGE (V_{DD}-V_O)

V_{DD}=5.0±0.25V

Temperature	STN-H
T _a = -20°C	4.6
T _a = 0°C	4.4
T _a = 25°C	4.2
T _a = 50°C	4.0
T _a =70°C	3.8

6.0 BACKLIGHT SPECIFICATIONS:

T_a=20°C,60%RH,Darkroom.

Item	Symbol	Typ.	Max.	Unit
LED input voltage	V _{LED+}	5	6	V
LED input current	I _{LED}	170	180	mA
Built-in current limiting resistor	R1	-	-	Ohms, W
External current limiting resistor (recommended)	R2	4.7Ohm 1/2W	-	Ohms, W
Number of nodes	N	17	-	-

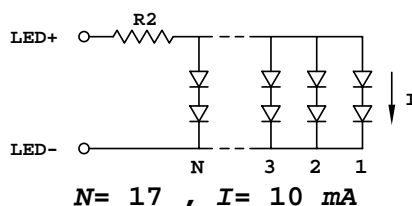

7.0 POWER SUPPLY

• STN-H

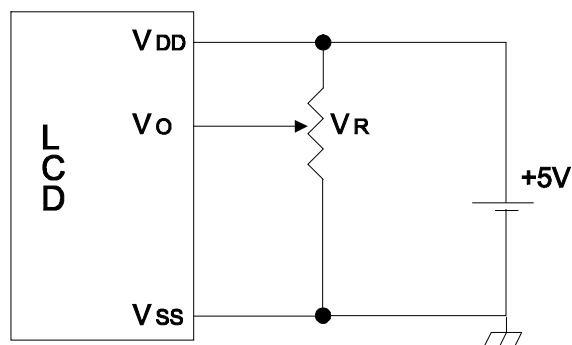

V_R= 10K - 20K ohm

8.0 INTERFACE DESCRIPTION

Pin No.	Symbol	I/O	Function
1	V _{SS}	-	Ground (0V), LED-
2	V _{DD}	-	Logic Supply Voltage (+5V)
3	V _O	-	LC Drive voltage for contrast adjustment
4	RS	I	Register Select 0: Instruction Register 1: Data Register
5	R/W	I	Read / Write 0: Data Write (Module←MPU) 1: Data Read (Module→MPU)
6	E	I	Enable Signal Active High (H→L)
7	DB0	I/O	Bi-directional data bus line 0
8	DB1	I/O	Bi-directional data bus line 1
9	DB2	I/O	Bi-directional data bus line 2
10	DB3	I/O	Bi-directional data bus line 3
11	DB4	I/O	Bi-directional data bus line 4
12	DB5	I/O	Bi-directional data bus line 5
13	DB6	I/O	Bi-directional data bus line 6
14	DB7	I/O	Bi-directional data bus line 7
15	V _{LED+}	-	Anode (+): LED backlight input voltage
16	V _{LED-}	-	Cathode (-): LED backlight input voltage
BL1	V _{LED+}	-	Anode (+): LED backlight input voltage
BL2	V _{LED-}	-	Cathode (-): LED backlight input voltage

9.0 BLOCK DIAGRAM:

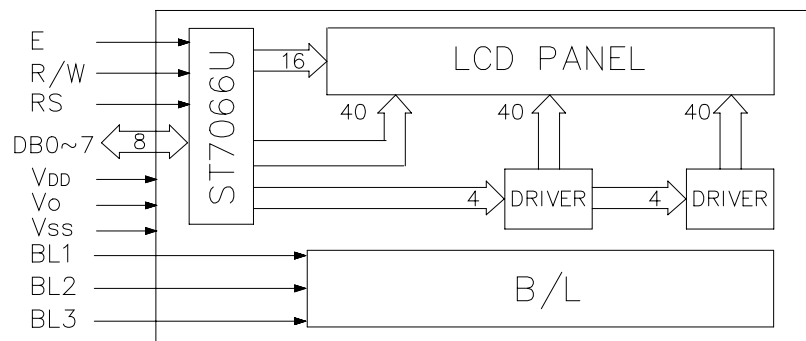

10.0 TIMING CHARACTERISTICS

Item	Symbol	Min.	Typ.	Max.	Unit
Enable cycle time	T_{cycE}	1.0	-	-	nS
Enable pulse width	PW_{EH}	450	-	-	nS
Enable rise / fall time	t_{Er}/t_{Ef}	-	-	25	nS
Address set-up time	t_{AS}	140	-	-	nS
Address hold time	t_{AH}	10	-	-	nS
Data delay time	t_{DDR}	-	-	320	nS
Data hold time (Write)	t_{DHW}	10	-	-	nS
Data hold time (Read)	t_{DHR}	20	-	-	nS
Data set-up time	t_{DSW}	195	-	-	nS

WRITE OPERATION

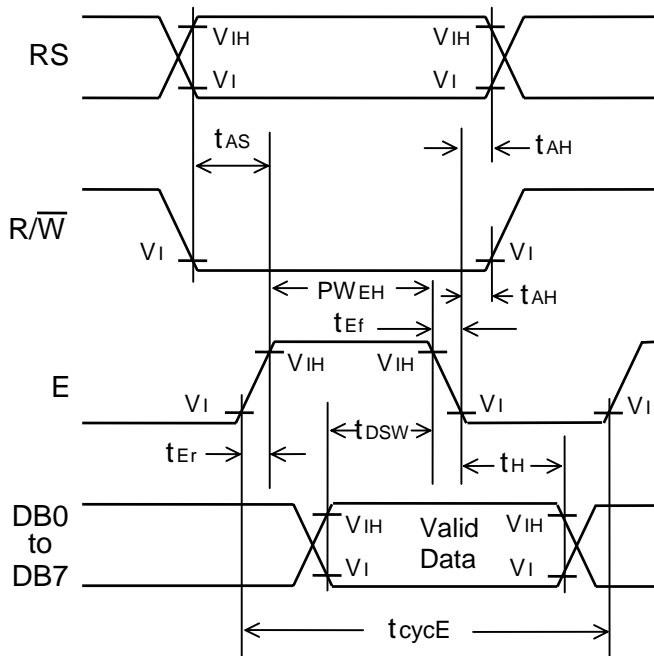

READ OPERATION

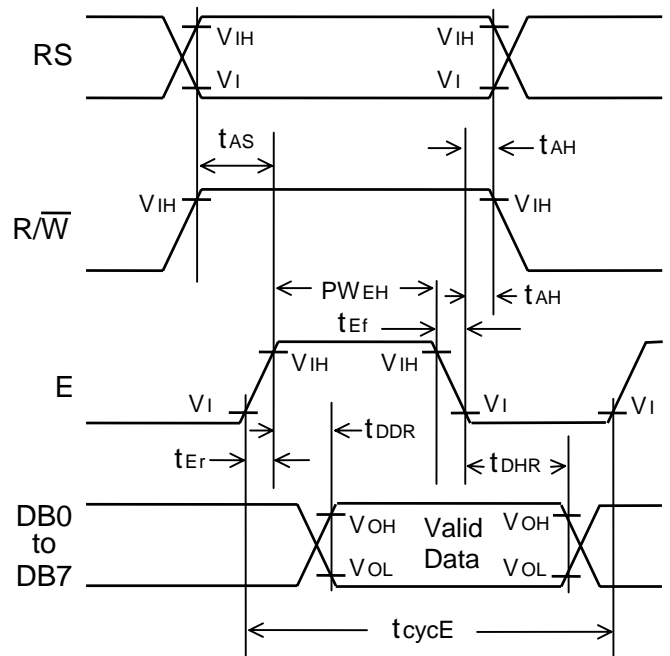

11.0 DD RAM ADDRESS vs. DISPLAY POSITION

Character	1	2	3	4	5	6	7	8	9	10	11	---	22	23	24
Line 1	00	01	02	03	04	05	06	07	08	09	0A	---	16	17	18
Line 2	40	41	42	43	44	45	46	47	48	49	4A	---	56	57	58

12.0 OPTICAL CHARACTERISTICS

Item	Symbol	Test Condition	Min.	Typ.	Max.	Unit
Contrast ratio STN-H	K	$\theta=20^\circ \theta=0^\circ$	5	-	-	-
Viewing angle STN-H	$\theta_2-\theta_1$	$\theta=0^\circ K \geq 1.4$	40	-	-	Deg.
	θ	$\theta=20^\circ K=1.4$	± 40	-	-	Deg.
Response time Rise	t_r	$\theta=20^\circ \theta=0^\circ$	-	150	250	mS
Fall	t_f	$\theta=20^\circ \theta=0^\circ$	-	150	250	mS

DEFINITION OF CONTRAST

$$K = \frac{\text{Brightness of non-selected}}{\text{Brightness of selected}}$$

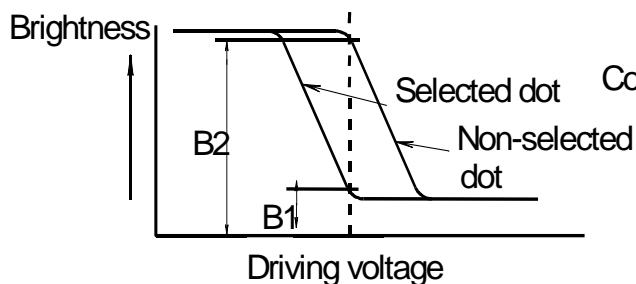

CONTRAST VERSUS

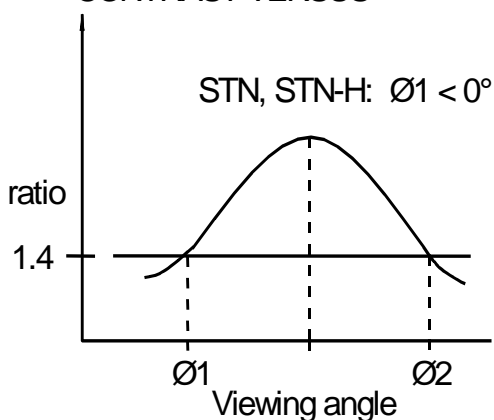

DEFINITION OF ANGLES θ AND DEFINITION OF OPTICAL RESPONSE

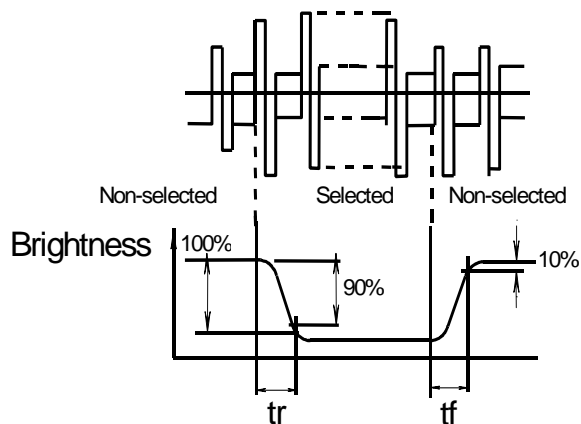
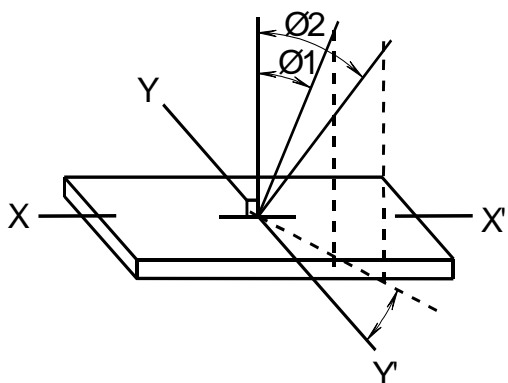

14.0 PART NUMBER DESCRIPTION FOR AVAILABLE OPTIONS

LC4427①②2C24③④⑤

①

Polarizer Type

B = Transflective: light background with LED backlight

②

Backlight Color

G = Yellow-green (standard)

③

Fluid Type and Power Supply

H = STN-H with +5VDC operation

④

Fluid Type

N = STN-H

⑤

Background Color for STN

G = Gray background

Y = Yellow background