

# LIQUID CRYSTAL DISPLAY MODULE

## Standard Product Specification

<b>PRODUCT NUMBER</b>	<b>LC4821</b>
-----------------------	---------------

INTERNAL APPROVALS				
Quality Mgr	Product Mgr	Project Leader	Electr. Eng	Document Control
Date:	Date:	Date:	Date:	Date:

- Approval for Specification only**
- Approval for Specification and Sample**

Sample no.:

Date:

ISIR no.:

# TABLE OF CONTENTS

<b>1</b>	<b>DESCRIPTION &amp; MAIN FEATURES .....</b>	<b>4</b>
1.1	DESCRIPTION.....	4
1.2	MECHANICAL CHARACTERISTICS.....	4
1.3	MECHANICAL DRAWING .....	5
<b>2</b>	<b>ELECTRICAL SPECIFICATION.....</b>	<b>6</b>
2.1	ABSOLUTE MAXIMUM RATINGS .....	6
2.2	ELECTRICAL CHARACTERISTICS .....	6
2.3	RECOMMENDED LC DRIVE VOLTAGE (VDD-VO).....	7
2.4	INTERFACE PIN ASSIGNMENT .....	7
2.5	BLOCK DIAGRAM .....	8
2.6	POWER SUPPLY CIRCUIT .....	8
2.7	TIMING CHARACTERISTICS .....	8
2.8	AC CHARACTERISTICS .....	9
2.9	TIMING CHARACTERISTICS.....	10
2.10	CHARACTER FONT .....	11
<b>3</b>	<b>OPTICAL SPECIFICATION.....</b>	<b>12</b>
3.1	OPTICAL CHARACTERISTICS.....	12
<b>4</b>	<b>BACKLIGHT SPECIFICATION .....</b>	<b>14</b>
4.1	BACKLIGHT CHARACTERISTICS.....	14
<b>5</b>	<b>QUALITY ASSURANCE SPECIFICATION .....</b>	<b>15</b>
5.1	CONFORMITY .....	15
5.2	DELIVERY ASSURANCE .....	15
5.3	DEALING WITH CUSTOMER COMPLAINTS .....	19
<b>6</b>	<b>RELIABILITY SPECIFICATION .....</b>	<b>20</b>
6.1	RELIABILITY TESTS .....	20
6.2	LIFE TIME.....	20
<b>7</b>	<b>PART NUMBER DESCRIPTIONS FOR AVAILABLE OPTIONS.....</b>	<b>21</b>
<b>8</b>	<b>HANDLING PRECAUTIONS.....</b>	<b>22</b>

**REVISION RECORD**

<b>Rev.</b>	<b>Date</b>	<b>Page</b>	<b>Chapt.</b>	<b>Comment</b>	<b>ECN no.</b>
A	04/03/03			Initial Standard Product Release	E1438
B	10/21/04			Update recommended LC drive voltage.	E1783
C	06/03/05			Updated DCA release.	E1935

# 1 DESCRIPTION & MAIN FEATURES

## 1.1 Description

---

Dot matrix display module consisting of a Liquid Crystal Display, CMOS driver and controller LSI, printed circuit board and metal support frame and array type Light Emitting Diode (LED) backlight.

Available LC fluids types are: STN (Supertwisted nematic), STN-H (Extended temperature range STN).

## 1.2 Mechanical Characteristics

---

ITEM	SPECIFICATION	UNIT
Module Dimensions	98.8 (W) x 60.2 (H) x 14.6 Max (D)	mm
Display Format	4 Lines x 20 Characters	--
Character Font Format	5 (W) x 8 (H) with attached cursor	dots
Duty Ratio	1/16	--
Dot Size	0.55 (W) x 0.55 (H)	mm
Dot Pitch	0.60 (W) x 0.60 (H)	mm
Character Size	2.95 (W) x 4.75 (H)	mm
Active Area	70.4 (W) x 20.8 (H)	mm
Viewing Area	76.0 (W) x 25.5 (H)	mm

### 1.3 MECHANICAL DRAWING

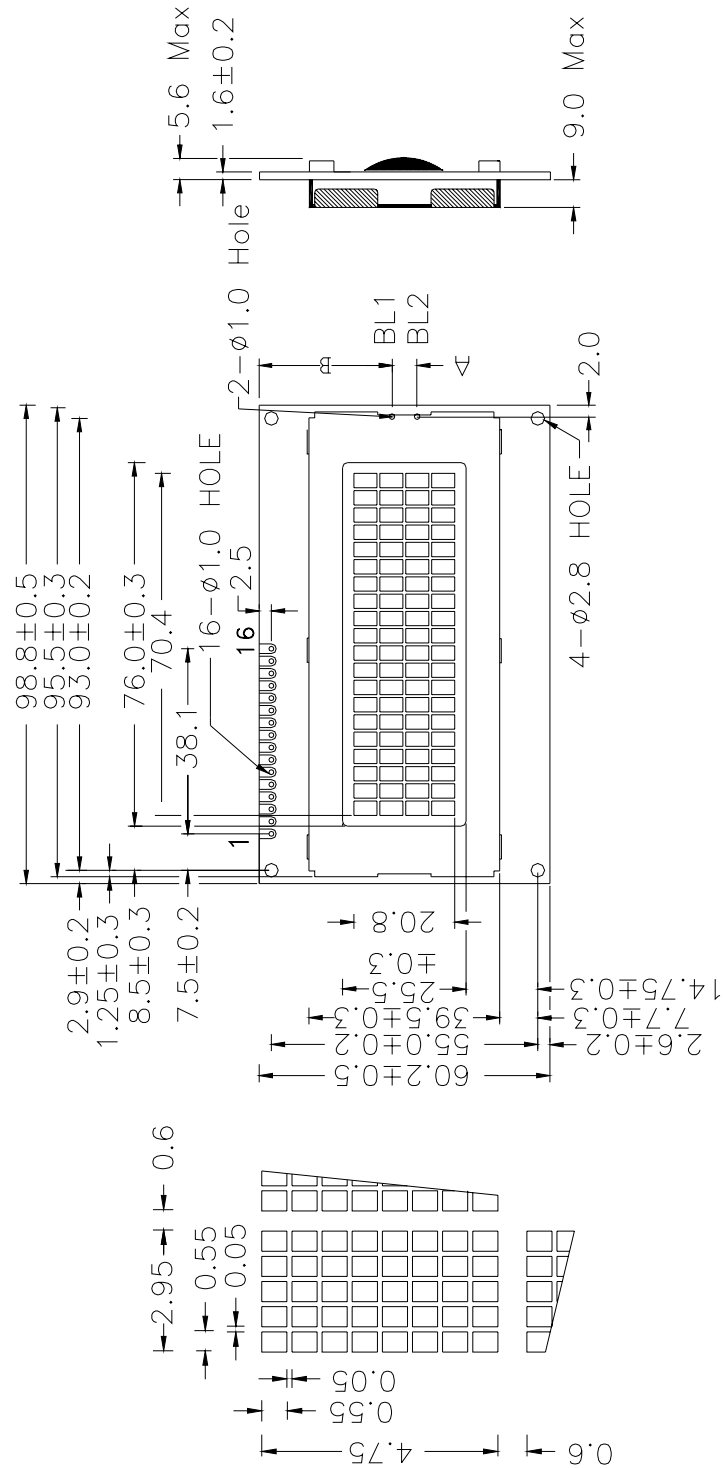

## 2 ELECTRICAL SPECIFICATION

### 2.1 ABSOLUTE MAXIMUM RATINGS

VSS = 0 V, Ta = 25 °C

Item	Symbol	Min	Max	Unit	Note
Power Supply Voltage	V <sub>DD</sub>	0	6.0	V	
LC driver supply voltage	V <sub>DD</sub> -V <sub>O</sub>	4.0	10.0	V	
Operating Temperature	Top	-20	+70	°C	Note 1,3
Storage Temperature	Tst	-30	+80	°C	Note 2
Humidity: Operating (@40°C,	--	--	65%		Note 4
Humidity: Non-operating (@40°C.	--	--	90%		Note 4

Note 1: Background colour changes slightly depending on ambient temperature. This phenomenon is reversible. Ta ≤ 70 °C: 75% RH max

Note 2: Ta ≤ 80 °C: 75% RH max

Note 3: Tested to 100 hrs.

Note 4: Refers to non-condensing conditions.

Note 5: It is not recommended to operate EL lamp above 50°C.

### 2.2 ELECTRICAL CHARACTERISTICS

VSS = 0 V, Ta = 25 °C

Item	Symbol	Condition	Min	Typ	Max	Unit
Input Voltage	V <sub>ILC</sub>	Ta = 25°C	0	--	1.0	V
	V <sub>IHC</sub>	Ta = 25°C	2.4	--	V <sub>DD</sub>	V
Output Voltage	V <sub>OH</sub>	I <sub>OH</sub> =0.205mA	2.4	--	--	V
	V <sub>OL</sub>	I <sub>OL</sub> =1.2mA	--	--	0.4	V
Current Consumption	* I <sub>DD</sub>	V <sub>DD</sub> = 5.0V	--	3	--	mA

\*I<sub>DD</sub> measurement condition is for all patterns ON

## 2.3 RECOMMENDED LC DRIVE VOLTAGE (VDD-VO)

Temperature	STN	STN-H
Ta = -20°C	--	4.7
Ta = 0°C	4.5	4.5
Ta = 25°C	4.4	4.4
Ta = 50°C	4.3	4.3
Ta = 70°C	--	4.2

## 2.4 INTERFACE PIN ASSIGNMENT

No.	Symbol	I/O	Function
1	V <sub>SS</sub>	--	Ground (0V), LED-
2	V <sub>DD</sub>	--	Logic Supply Voltage (+5V)
3	V <sub>O</sub>	--	LC Drive voltage for contrast adjustment
4	RS	I	Register Select 0: Instruction Register 1: Data Register
5	R/W	I	Read / Write 0: Data Write (Module ← MPU) 1: Data Read (Module → MPU)
6	E	I	Enable Signal Active High (H → L)
7	DB0	I/O	Bi-directional data bus line 0
8	DB1	I/O	Bi-directional data bus line 1
9	DB2	I/O	Bi-directional data bus line 2
10	DB3	I/O	Bi-directional data bus line 3
11	DB4	I/O	Bi-directional data bus line 4
12	DB5	I/O	Bi-directional data bus line 5
13	DB6	I/O	Bi-directional data bus line 6
14	DB7	I/O	Bi-directional data bus line 7
15	VLED+	--	Anode (+) LED backlight input voltage
16	VLED-	--	Cathode (-) LED backlight input voltage
BL1	VLED+	--	Anode (+) LED backlight input voltage
BL2	VLED-	--	Cathode (-) LED backlight input voltage

## 2.5 BLOCK DIAGRAM

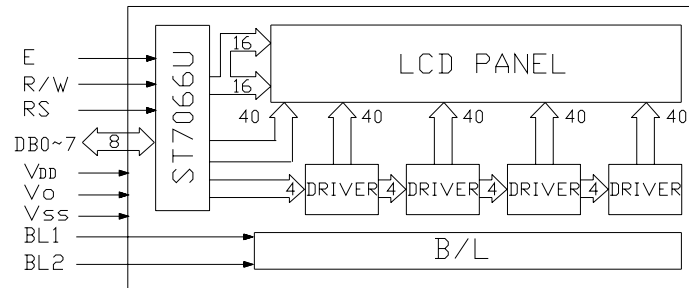

## 2.6 POWER SUPPLY CIRCUIT

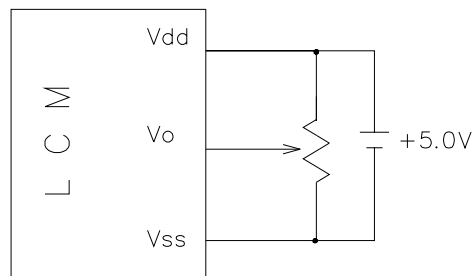

RECOMMENDED  $V_R$ : 10Kohm ~ 20Kohm

## 2.7 TIMING CHARACTERISTICS

Note: Please reference the manufacturer's datasheet for the Sitronix ST7066U controller.



## 2.8 AC CHARACTERISTICS

(TA =25°C, VCC=5V)

Symbol	Characteristics	Test Condition	Min.	Typ.	Max.	Unit
<i>Internal Clock Operation</i>						
f <sub>OSC</sub>	OSC Frequency	R = 91KΩ	190	270	350	KHz
<i>External Clock Operation</i>						
f <sub>EX</sub>	External Frequency	-	125	270	410	KHz
	Duty Cycle	-	45	50	55	%
T <sub>R</sub> , T <sub>F</sub>	Rise/Fall Time	-	-	-	02	IS
<i>Write Mode (Writing data from MPU to ST7066U)</i>						
T <sub>C</sub>	Enable Cycle Time	Pin E	1200	-	-	ns
T <sub>PW</sub>	Enable Pulse Width	Pin E	140	-	-	ns
T <sub>R</sub> , T <sub>F</sub>	Enable Rise/Fall Time	Pin E	-	-	25	ns
T <sub>AS</sub>	Address Setup Time	Pins: RS,RW,E	0	-	-	ns
T <sub>AH</sub>	Address Hold Time	Pins: RS,RW,E	10	-	-	ns
T <sub>DSW</sub>	Data Setup Time	Pins: DBO – DB7	40	-	-	ns
T <sub>H</sub>	Data Hold Time	Pins: DBO – DB7	10	-	-	ns
<i>Read Mode (Reading Data from ST7066U to MPU)</i>						
T <sub>C</sub>	Enable Cycle Time	Pin E	1200	-	-	ns
T <sub>PW</sub>	Enable Pulse Width	Pin E	140	-	-	ns
T <sub>R</sub> , T <sub>F</sub>	Enable Rise/Fall Time	Pin E	-	-	25	ns
T <sub>AS</sub>	Address Setup Time	Pins: RS,RW,E	0	-	-	ns
T <sub>AH</sub>	Address Hold Time	Pins: RS,RW,E	10	-	-	ns
T <sub>DSW</sub>	Data Setup Time	Pins: DBO – DB7	-	-	100	ns
T <sub>H</sub>	Data Hold Time	Pins: DBO - DB7	10	-	-	ns
<i>Interface Mode with LCD Driver(ST7065)</i>						
T <sub>CWH</sub>	Clock Pulse with High	Pins' CL 1, CL2	800	-	-	ns
T <sub>CWL</sub>	Clock Pulse with Low	Pins: CL 1, CL2	800	-	-	ns
T <sub>CST</sub>	Clock Setup Time	Pins: CL 1, CL2	500	-	-	ns
T <sub>SU</sub>	Data Setup Time	Pin: 0	300	-	-	ns
T <sub>DH</sub>	Data Hold Time	Pin: D	300	-	-	ns
T <sub>DM</sub>	M Delay Time	Pin: M	0	-	2000	ns

## 2.9 TIMING CHARACTERISTICS

- Writing data from MPU to ST7066U

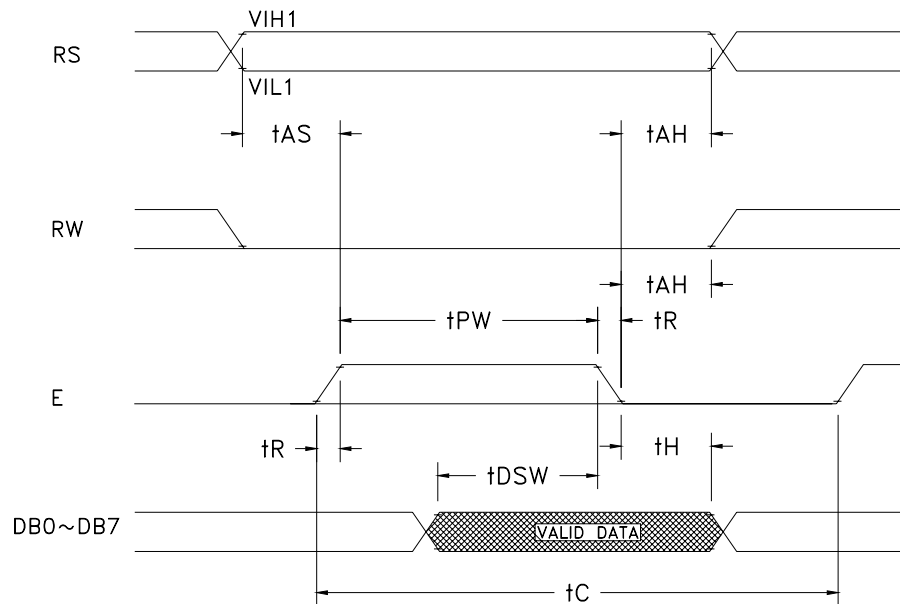

- Reading data from ST7066U to MPU

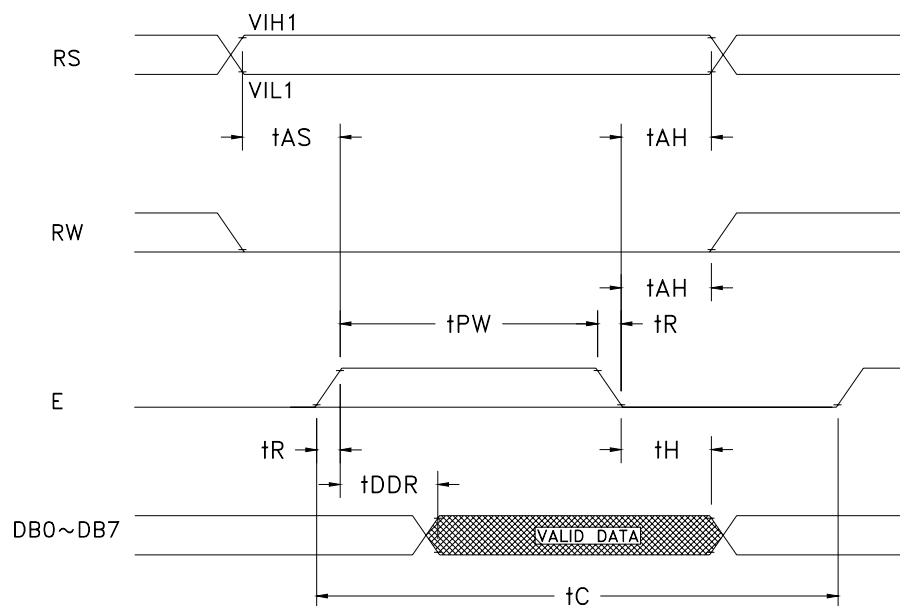

## 2.10 CHARACTER FONT

NO.7066-0A

b7-b4 b3-b0	0000	0001	0010	0011	0100	0101	0110	0111	1000	1001	1010	1011	1100	1101	1110	1111
0000	CG RAM (1)			0	@	P	`	F			-	9	E	o	p	
0001	(2)		!	1	A	Q	a	q			.	7	†	4	ä	q
0010	(3)		"	2	B	R	b	r			Γ	Y	×	ρ	θ	
0011	(4)		#	3	C	S	c	s			∟	ウ	テ	ε	ε	∞
0100	(5)		\$	4	D	T	d	t			、	I	ト	†	μ	Ω
0101	(6)		%	5	E	U	e	u			.	オ	†	1	ε	U
0110	(7)		&	6	F	V	f	v			ヲ	カ	ニ	ヨ	ρ	Σ
0111	(8)		'	7	G	W	g	w			フ	†	又	ウ	g	π
1000	(1)		(	8	H	X	h	x			イ	ウ	*	ウ	†	×
1001	(2)		)	9	I	Y	i	y			ウ	†	ル	†	†	†
1010	(3)		*	:	J	Z	j	z			エ	コ	ノ	ノ	j	†
1011	(4)		+	:	K	L	k	l			*	オ	ヒ	ロ	×	†
1100	(5)		,	<	L	†	1	†			†	ウ	†	†	†	†
1101	(6)		-	=	M	J	m	†			ユ	ズ	†	†	†	†
1110	(7)		.	>	N	^	n	†			ヨ	セ	†	†	†	†
1111	(8)		/	?	O	_	o	†			ウ	†	†	†	†	†

### 3 OPTICAL SPECIFICATION

#### 3.1 OPTICAL CHARACTERISTICS

Ta = 25 °C

Item	Symbol	Condition	Min	Typ	Max	Unit	Note
Viewing Angle	0°	CR <sub>≥2</sub>	--	49	--	deg	1
	180°	CR <sub>≥2</sub>	--	58	--	deg	1
	90°	CR <sub>≥2</sub>	--	39	--	deg	2
	270°	CR <sub>≥2</sub>	--	37	--	deg	2
Contrast Ratio	CR	Ta = 25 °C	--	7.33	7.41	-	3
Response Time	Tr	Ta = 25 °C	--	48.2	300	ms	4
	Tf	Ta = 25 °C	--	98.7	300		
Driving Method	Duty	1/16					
	Bias	1/5					
LCD Type	STN - Positive						
Viewing Direction	6:00						

Note 1: definition of viewing angle  $\theta_1$  &  $\theta_2$

Note 2: definition of viewing angle  $\theta_3$  &  $\theta_4$

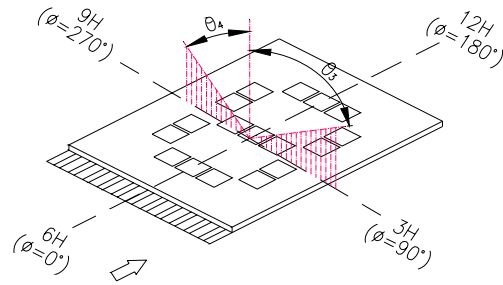
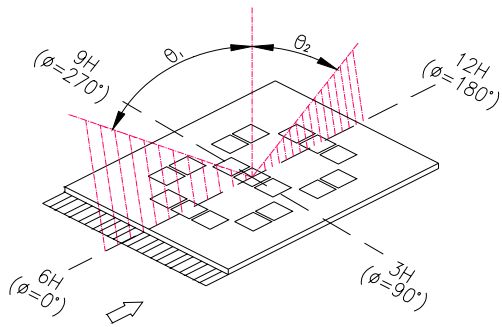

Note 3: definition of contrast ratio (CR)

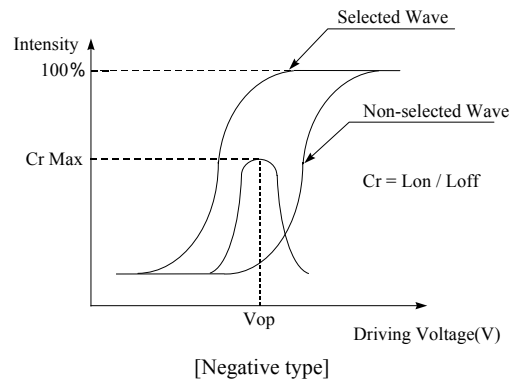
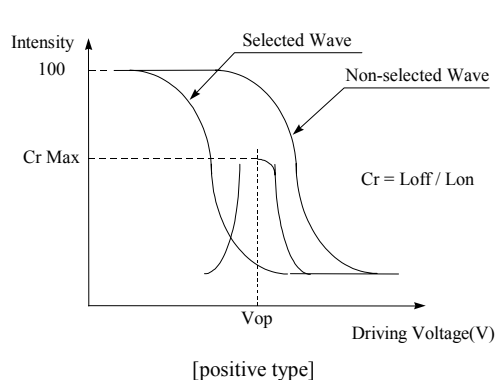

Note 4: definition of response time

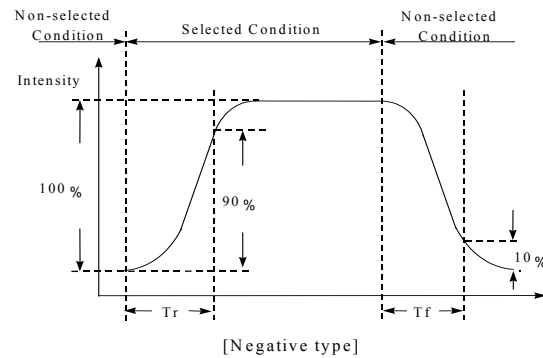
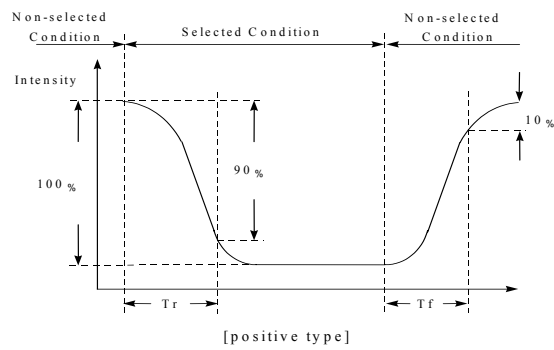

## 4 BACKLIGHT SPECIFICATION

### 4.1 BACKLIGHT CHARACTERISTICS

#### Array LED B/L operating range (Vin = 5V)

Item	Conditions	Standard			Unit
		Min.	Typ.	Max.	
Input voltage	Ta = 25 C	---	5.0	---	V(DC)
Current consumption	Ta = 25 C		280		mA
Average brightness (B/L only) (Ta = 25 C, IL = 280 mA)	Test when connecting after 3 min. Ta = 25 C (max. contrast)				cd/m2 (Note 3)
	Yellow-green array B/L	---	160	---	
Brightness uniformity	Ta = 25 C , IL = 280 mA	80	---	---	% (Note 4)
Lamp life	Ta = 25 C , IL = 280 mA Humidity : 30%RH ~ 85%RH	---	50,000	---	Hrs (Note 5)
Operating Temp.	Humidity : 30%RH ~ 85%RH	-20	---	70	C
Storage Temp.	Humidity : 30%RH ~ 85%RH	-30	---	80	C
limit resistor (R2)	Ta = 25 C	---	3.3	---	OHM (Note 2)

Note 2: Suggest BL current limit resistor on customer board.

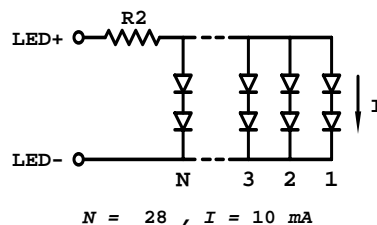

3: Average brightness of 3 points when B/L is used at the beginning.

4: Brightness uniformity = (MIN / MAX) x 100 %

5: Half of the original average brightness

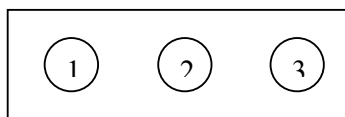

## 5 QUALITY ASSURANCE SPECIFICATION

### 5.1 CONFORMITY

The performance, function and reliability of the shipped products conform to the Product Specification.

### 5.2 DELIVERY ASSURANCE

#### 5.2.1 Delivery inspection standards

- MIL-STD-105E, general inspection level II, single sampling level;
- IPC-AA610 rev. C, class 2 electronic assemblies standard

The quality assurance levels are shown below:

Rank	Item Inspected	Defect type	AQL	Remark
Major defect	Display	Non display	0.25%	Fit/Function defect
		Over current		
		Missing segment		
		Wrong viewing direction		
		Incorrect operating		
		Backlight OFF		
	Backlight flashing			
Dimension	PCB and bezel out of specification			
Minor defect	LCD	Black and white spot	1.0%	Appearance defect
		Black and white lines		
		Polariser scratch		
		Bubbles in polariser		
		Segment deformation, pin hole		
		Colour uniformity		
		Glass chip		
	COB	Wire bond pad exposed		
		Insufficient covering with resin (wire bond line exposed)		
		Bubble, dust on COB		
PCB	Dust, solder ball on PCB			
	Pad scratch			
Tray	Particles	Every tray		
Total			1.0%	

### 5.2.2 Zone definition

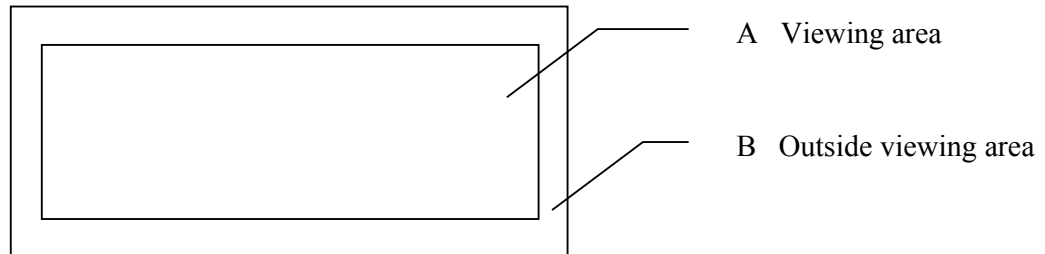

### 5.2.3 Visual inspection

- Inspect under 2x20W or 40W fluorescent lamp (approximately 3000 lux) leaving 25 to 30 cm between the module and the lamp and 30 cm between the module and the eye (measuring position).
- Appearance is inspected at the best contrast voltage (best contrast is adjusted considering clearness and crosstalk on screen).
- Inspect the module at 45° right and left, top and bottom.
- Use the optimum viewing angle during the contrast inspection.

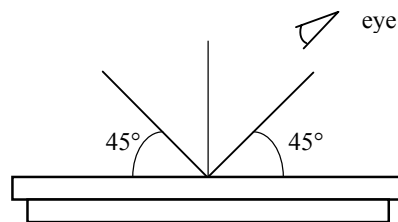



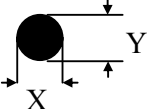
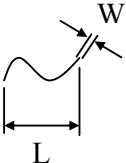
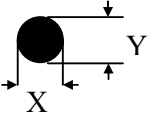
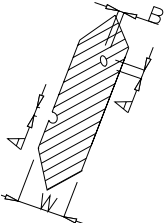

### 5.2.3.1 Standard of appearance inspection

Units: mm

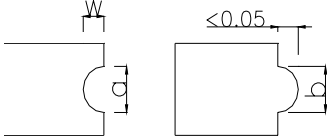
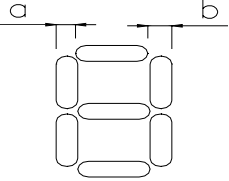
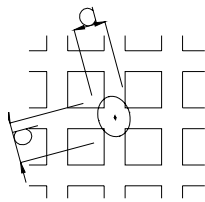
No	Item	Criteria																																			
1	Black spot, white spot, dust	<p>Round type: as per following drawing  <math>\varnothing = (X+Y)/2</math></p>  <table border="1" data-bbox="813 516 1378 722"> <thead> <tr> <th colspan="3">Acceptable quantity</th> </tr> <tr> <th>Size</th> <th>Zone A</th> <th>Zone B</th> </tr> </thead> <tbody> <tr> <td><math>\varnothing &lt; 0.1</math></td> <td>Any number</td> <td rowspan="4">Any number</td> </tr> <tr> <td><math>0.1 &lt; \varnothing &lt; 0.2</math></td> <td>2</td> </tr> <tr> <td><math>0.2 &lt; \varnothing &lt; 0.25</math></td> <td>1</td> </tr> <tr> <td><math>0.25 &lt; \varnothing</math></td> <td>0</td> </tr> </tbody> </table> <p>Line type: as per following drawing</p>  <table border="1" data-bbox="664 787 1378 984"> <thead> <tr> <th colspan="4">Acceptable quantity</th> </tr> <tr> <th>Length</th> <th>Width</th> <th>Zone A</th> <th>Zone B</th> </tr> </thead> <tbody> <tr> <td>--</td> <td><math>W \leq 0.02</math></td> <td>Any number</td> <td rowspan="4">Any number</td> </tr> <tr> <td><math>L \leq 3.0</math></td> <td><math>0.02 &lt; W \leq 0.03</math></td> <td rowspan="2">2</td> </tr> <tr> <td><math>L \leq 2.5</math></td> <td><math>0.03 &lt; W \leq 0.05</math></td> </tr> <tr> <td>--</td> <td><math>0.05 &lt; W</math></td> <td>As round type</td> </tr> </tbody> </table> <p>Total acceptable quantity: 3</p>	Acceptable quantity			Size	Zone A	Zone B	$\varnothing < 0.1$	Any number	Any number	$0.1 < \varnothing < 0.2$	2	$0.2 < \varnothing < 0.25$	1	$0.25 < \varnothing$	0	Acceptable quantity				Length	Width	Zone A	Zone B	--	$W \leq 0.02$	Any number	Any number	$L \leq 3.0$	$0.02 < W \leq 0.03$	2	$L \leq 2.5$	$0.03 < W \leq 0.05$	--	$0.05 < W$	As round type
Acceptable quantity																																					
Size	Zone A	Zone B																																			
$\varnothing < 0.1$	Any number	Any number																																			
$0.1 < \varnothing < 0.2$	2																																				
$0.2 < \varnothing < 0.25$	1																																				
$0.25 < \varnothing$	0																																				
Acceptable quantity																																					
Length	Width	Zone A	Zone B																																		
--	$W \leq 0.02$	Any number	Any number																																		
$L \leq 3.0$	$0.02 < W \leq 0.03$	2																																			
$L \leq 2.5$	$0.03 < W \leq 0.05$																																				
--	$0.05 < W$	As round type																																			
2	Polariser scratch	Scratch on protective film is permitted Scratch on polariser: same as No. 1																																			
3	Polariser bubble	<p><math>\varnothing = (X+Y)/2</math></p>  <table border="1" data-bbox="813 1182 1378 1388"> <thead> <tr> <th colspan="3">Acceptable quantity</th> </tr> <tr> <th>Size</th> <th>Zone A</th> <th>Zone B</th> </tr> </thead> <tbody> <tr> <td><math>\varnothing &lt; 0.2</math></td> <td>Any number</td> <td rowspan="4">Any number</td> </tr> <tr> <td><math>0.2 &lt; \varnothing &lt; 0.5</math></td> <td>2</td> </tr> <tr> <td><math>0.5 &lt; \varnothing &lt; 1.0</math></td> <td>1</td> </tr> <tr> <td><math>1.0 &lt; \varnothing</math></td> <td>0</td> </tr> </tbody> </table> <p>Total acceptable quantity: 3</p>	Acceptable quantity			Size	Zone A	Zone B	$\varnothing < 0.2$	Any number	Any number	$0.2 < \varnothing < 0.5$	2	$0.5 < \varnothing < 1.0$	1	$1.0 < \varnothing$	0																				
Acceptable quantity																																					
Size	Zone A	Zone B																																			
$\varnothing < 0.2$	Any number	Any number																																			
$0.2 < \varnothing < 0.5$	2																																				
$0.5 < \varnothing < 1.0$	1																																				
$1.0 < \varnothing$	0																																				
4	Segment deformation	<p>1.a. Pin hole on segmented display</p> <p>W: segment width  <math>\varnothing = (A+B)/2</math></p>  <table border="1" data-bbox="813 1549 1378 1688"> <thead> <tr> <th colspan="2">Acceptable quantity</th> </tr> <tr> <th>Width</th> <th><math>\varnothing</math></th> </tr> </thead> <tbody> <tr> <td><math>W \leq 0.4</math></td> <td><math>\varnothing \leq 0.2</math> and <math>\varnothing \leq 1/2 W</math></td> </tr> <tr> <td><math>W &gt; 0.4</math></td> <td><math>\varnothing \leq 0.25</math> and <math>\varnothing \leq 1/3 W</math></td> </tr> </tbody> </table> <p>Total acceptable quantity: 1 defect per segment Pin holes with <math>\varnothing</math> under 0.10 mm are acceptable</p>	Acceptable quantity		Width	$\varnothing$	$W \leq 0.4$	$\varnothing \leq 0.2$ and $\varnothing \leq 1/2 W$	$W > 0.4$	$\varnothing \leq 0.25$ and $\varnothing \leq 1/3 W$																											
Acceptable quantity																																					
Width	$\varnothing$																																				
$W \leq 0.4$	$\varnothing \leq 0.2$ and $\varnothing \leq 1/2 W$																																				
$W > 0.4$	$\varnothing \leq 0.25$ and $\varnothing \leq 1/3 W$																																				

No	Item	Criteria																												
5	Segment deformation	<p>1b. Pin hole on dot matrix display</p>  <table border="1" data-bbox="1003 367 1377 535"> <thead> <tr> <th colspan="2">Acceptable quantity</th> </tr> <tr> <th>Size</th> <th></th> </tr> </thead> <tbody> <tr> <td>a,b&lt;0.1</td> <td>Any number</td> </tr> <tr> <td>(a+b)/2≤0.1</td> <td>Any number</td> </tr> <tr> <td>0.5&lt;∅&lt;1.0</td> <td>3</td> </tr> </tbody> </table> <p>Total acceptable quantity: 7</p> <p>2. Segments / dots with different width</p>  <table border="1" data-bbox="1003 730 1377 829"> <thead> <tr> <th colspan="2">Acceptable</th> </tr> <tr> <th>a≥b</th> <th>a/b≤4/3</th> </tr> <tr> <th>a&lt;b</th> <th>a/b&gt;4/3</th> </tr> </thead> </table> <p>3. Alignment layer defect</p> <p>∅ = (a+b)/2</p>  <table border="1" data-bbox="1003 892 1377 1102"> <thead> <tr> <th colspan="2">Acceptable quantity</th> </tr> <tr> <th>Size</th> <th></th> </tr> </thead> <tbody> <tr> <td>∅≤0.4</td> <td>Any number</td> </tr> <tr> <td>0.4&lt;∅≤1.0</td> <td>5</td> </tr> <tr> <td>1.0&lt;∅≤1.5</td> <td>3</td> </tr> <tr> <td>1.5&lt;∅≤2.0</td> <td>2</td> </tr> </tbody> </table> <p>Total acceptable quantity: 7</p>	Acceptable quantity		Size		a,b<0.1	Any number	(a+b)/2≤0.1	Any number	0.5<∅<1.0	3	Acceptable		a≥b	a/b≤4/3	a<b	a/b>4/3	Acceptable quantity		Size		∅≤0.4	Any number	0.4<∅≤1.0	5	1.0<∅≤1.5	3	1.5<∅≤2.0	2
Acceptable quantity																														
Size																														
a,b<0.1	Any number																													
(a+b)/2≤0.1	Any number																													
0.5<∅<1.0	3																													
Acceptable																														
a≥b	a/b≤4/3																													
a<b	a/b>4/3																													
Acceptable quantity																														
Size																														
∅≤0.4	Any number																													
0.4<∅≤1.0	5																													
1.0<∅≤1.5	3																													
1.5<∅≤2.0	2																													
6	Colour uniformity	Level of sample for approval set as limit sample																												
7	Backlight	The backlight colour should correspond to the product specification Flashing and or unlit backlight is not allowed Dust larger than 0.25 mm is not allowed																												
8	COB	Exposed wire bond pad is not allowed Insufficient covering with resin is not allowed (wire bond line exposed) Dust or bubble on the resin are not allowed																												
9	PCB 	No unmelted solder paste should be present on PCB Cold solder joints, missing solder connections, or oxidation are not allowed No residue or solder balls on PCB are allowed Short circuits on components are not allowed																												
10	Tray particles	<table border="1" data-bbox="738 1648 1396 1816"> <thead> <tr> <th></th> <th>Size</th> <th>Quantity</th> </tr> </thead> <tbody> <tr> <td rowspan="2">On tray</td> <td>∅&lt;0.2</td> <td>Any number</td> </tr> <tr> <td>∅&gt;0.25</td> <td>4</td> </tr> <tr> <td rowspan="2">On display</td> <td>∅≥0.25</td> <td>2</td> </tr> <tr> <td>L = 3</td> <td>1</td> </tr> </tbody> </table>		Size	Quantity	On tray	∅<0.2	Any number	∅>0.25	4	On display	∅≥0.25	2	L = 3	1															
	Size	Quantity																												
On tray	∅<0.2	Any number																												
	∅>0.25	4																												
On display	∅≥0.25	2																												
	L = 3	1																												

## **5.3 DEALING WITH CUSTOMER COMPLAINTS**

---

### **5.3.1 Non-conforming analysis**

Purchaser should supply Densitron with detailed data of non-conforming sample. After accepting it, Densitron should complete the analysis in two weeks from receiving the sample.

If the analysis cannot be completed on time, Densitron must inform the purchaser.

### **5.3.2 Handling of non-conforming displays**

If any non-conforming displays are found during customer acceptance inspection which Densitron is clearly responsible for, return them to Densitron.

Both Densitron and customer should analyse the reason and discuss the handling of non-conforming displays when the reason is not clear.

Equally, both sides should discuss and come to agreement for issues pertaining to modification of Densitron quality assurance standard.

## 6 RELIABILITY SPECIFICATION

### 6.1 RELIABILITY TESTS

---

Test Item	Test Condition	Evaluation and assessment
Operation at high temperature and humidity	40°C±2°C 90% RH for 240 hours	No abnormalities in function* and appearance**
Operation at high temperature	70°C±2°C for 240 hours	No abnormalities in function* and appearance**
Low temperature	-20°C±2°C for 240 hours	No abnormalities in function* and appearance**
Heat Shock	-20~+70°C Left for 1 hour at each temperature, transition time 5 minutes repeated 10 times.	No abnormalities in function* and appearance**
Vibration	Sweep for 1 minute at 10Hz, 55Hz, 10Hz, amplitude 1.5mm for 2 hours in the X, Y and Z directions.	No abnormalities in function* and appearance**
Drop Shock	Drop Shock	No abnormalities in function* and appearance**

### 6.2 LIFE TIME

---

Item	Description
1	Function, performance, appearance, etc. shall be free from remarkable deterioration within 50,000 hours under ordinary operating and storage conditions of room temperature (25±10 °C), normal humidity (45±20% RH), and in area not exposed to direct sunlight.

## 7 PART NUMBER DESCRIPTIONS FOR AVAILABLE OPTIONS

LC4821①②4C20④⑤⑥  
③

### ① POLARISER OPTION

B = Transflective: light background, with backlight.  
(EL or LED backlight).

### ② LED BACKLIGHT COLOUR

G = Yellow-green (standard)

### ③ DISPLAY FORMAT

### ④ FLUID TYPE AND POWER SUPPLY

H = STN-H, extended temp with  $\pm 5$ VDC operation

### ⑤ FLUID TYPE AND TN VIEWING ANGLE

N = STN-H

### ⑥ TN TEMPERATURE RANGE OR STN/NTN BACKGROUND COLOUR

G = Grey mode STN/NTN (with A, B, F polarisers)

Y = Yellow mode STN/NTN (with A, B, F polarisers)

## 8 HANDLING PRECAUTIONS

### *Safety*

If the LCD panel breaks, be careful not to get the liquid crystal fluid in your mouth or in your eyes. If the liquid crystal touches your skin or clothes, wash it off immediately using soap and plenty of water.

### *Mounting and Design*

Place a transparent plate (e.g. acrylic, polycarbonate or glass) on the display surface to protect the display from external pressure. Leave a small gap between the transparent plate and the display surface.

When assembling with a zebra connector, clean the surface of the pads with alcohol and keep the surrounding air very clean.

Design the system so that no input signal is given unless the power supply voltage is applied.

### *Caution during LCD cleaning*

Lightly wipe the display surface with a soft cloth soaked with Isopropyl alcohol, Ethyl alcohol or Trichlorotrifluoroethane.

Do not wipe the display surface with dry or hard materials that will damage the polariser surface.

Do not use aromatic solvents (toluene and xylene), or ketonic solvents (ketone and acetone).

### *Caution against static charge*

As the display uses C-MOS LSI drivers, connect any unused input terminal to VDD or VSS. Do not input any signals before power is turned on. Also, ground your body, work/assembly table and assembly equipment to protect against static electricity.

### *Packaging*

Displays use LCD elements, and must be treated as such. Avoid strong shock and drop from a height. To prevent displays from degradation, do not operate or store them exposed directly to sunshine or high temperature/humidity.

### *Caution during operation*

It is indispensable to drive the display within the specified voltage limit since excessive voltage shortens its life. Direct current causes an electrochemical reaction with remarkable deterioration of the display quality. Give careful consideration to prevent direct current during ON/OFF timing and during operation. Response time is extremely delayed at temperatures lower than the operating temperature range while, at high temperatures, displays become dark. However, this phenomenon is reversible and does not mean a malfunction or a display that has been permanently damaged. If the display area is pushed on hard during operation, some graphics will be abnormally displayed but returns to a normal condition after turning off the display once. Even a small amount of condensation on the contact pads (terminals) can cause an electro-chemical reaction which causes missing rows and columns. Give careful attention to avoid condensation.

### *Storage*

Store the display in a dark place where the temperature is  $25^{\circ}\text{C} \pm 10^{\circ}\text{C}$  and the humidity below 50%RH. Store the display in a clean environment, free from dust, organic solvents and corrosive gases. Do not crash, shake or jolt the display (including accessories).