

LIQUID CRYSTAL DISPLAY MODULE

Standard Product Specification

PRODUCT NUMBER	LMR4055
---------------------------	----------------

INTERNAL APPROVALS		
Product Manager	Engineering	Document Control
Date:	Date:	Date:

TABLE OF CONTENTS

1	MAIN FEATURES.....	4
2	MECHANICAL SPECIFICATION.....	5
2.1	MECHANICAL CHARACTERISTICS.....	5
2.2	LABELLING & MARKING.....	5
2.3	MECHANICAL DRAWING.....	6
3	ELECTRICAL SPECIFICATION.....	7
3.1	ABSOLUTE MAXIMUM RATINGS.....	7
3.2	ELECTRICAL CHARACTERISTICS.....	7
3.3	RECOMMENDED LC DRIVE VOLTAGE (VDD-VO).....	8
3.4	INTERFACE PIN ASSIGNMENT.....	8
3.5	BLOCK DIAGRAM.....	9
3.6	POWER SUPPLY CIRCUIT.....	9
3.7	TIMING CHARACTERISTICS.....	9
4	OPTICAL SPECIFICATION.....	10
4.1	OPTICAL CHARACTERISTICS.....	10
5	BACKLIGHT SPECIFICATION.....	13
5.1	BACKLIGHT CHARACTERISTICS.....	13
6	QUALITY ASSURANCE SPECIFICATION.....	14
6.1	CONFORMITY.....	14
6.2	DELIVERY ASSURANCE.....	14
7	RELIABILITY SPECIFICATION.....	18
7.1	RELIABILITY TESTS.....	18
7.2	LIFE TIME.....	18
8	PART NUMBER DESCRIPTION FOR AVAILABLE OPTIONS.....	19
9	HANDLING PRECAUTIONS.....	20

REVISION RECORD

Rev.	Date	Page	Chap.	Comment	ECN no.
A	11/08/06	-	-	Initial DCA Release, ROHS	E3311

1 MAIN FEATURES

UNIT=MM

ITEM	CONTENTS	REMARK
Display Format	320 dots x 240 dots	
Colour	Monochrome	
Overall Dimensions	173.0 (W) x 109.9 (H) x 16.0 max. (D)	
Viewing Area	122.0 (W) x 92.0 (H)	
LCD Type	STN-Negative-Transmissive	
	FSTN-Positive-Transflective	
	FSTN-Negative-Transmissive	
Mode	Blue	
Viewing Angle	6 o'clock	
Duty Ratio	1/240	
Driver IC\Controller	N/A	
Backlight Type	LED	
Backlight Colour	White	
DC/DC Converter	Yes (optional)	
Operating Temperature	-20°C to +70°C	Note 1
Storage Temperature	-30°C to +80°C	Note 2

Note 1: Background colour changes slightly depending on ambient temperature. This phenomenon is reversible.

Ta≤70°C: 75% RH max.

Ta>70°C: absolute humidity must be lower than the humidity of 75%RH at 70°C

Note 2: Ta -30°C will be <48hrs, at 80°C will be <120hrs.

Product No.	LMR4055	REV. A
-------------	---------	--------

Page	4 / 20
------	--------

2 MECHANICAL SPECIFICATION

2.1 MECHANICAL CHARACTERISTICS

ITEM	CHARACTERISTIC	UNIT
Display Format	320 dots x 240 dots	--
Overall Dimensions	173.0 (W) x 109.0 (H) x 16.0 max (D)	mm
Viewing Area	122.0 (W) x 92.0 (H)	mm
Active Area	115.185 (W) x 86.385 (H)	mm
Dot Size	0.345 (W) x 0.345 (H)	mm
Dot Pitch	0.360 (W) x 0.360 (H)	mm
Weight	197	g

2.2 LABELLING & MARKING

NOTE: XX XXX Represent options refer to sheet 21.

DENSITRON LRM4055 XX XXX TAIWAN YYMM
--

2.3 MECHANICAL DRAWING

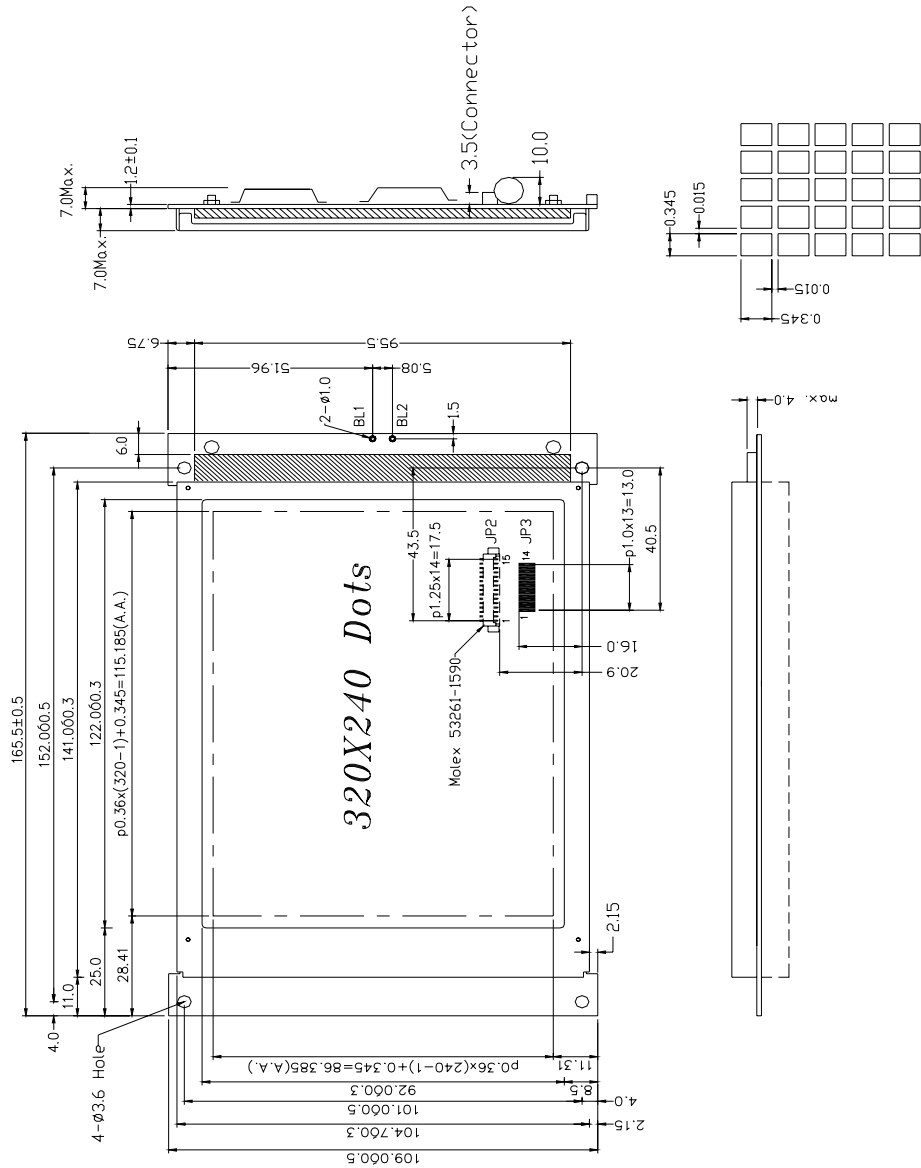

Product No.	LMR4055	REV. A
-------------	---------	--------

Page	6 / 20
------	--------

3 ELECTRICAL SPECIFICATION

3.1 ABSOLUTE MAXIMUM RATINGS

VSS = 0 V, Ta = 25 °C

Item	Symbol	Min	Max	Unit	Note
Power Supply Voltage	V _{DD} -V _{SS}	0	7.0	V	
Input Voltage	V _{in}	0	V _{dd}	V	
Static Electricity	Be sure that you are grounded when handling displays.				

3.2 ELECTRICAL CHARACTERISTICS

VSS = 0 V, Ta = 25 °C

Item	Symbol	Condition	Min	Typ	Max	Unit
Power Supply for Logic	V _{DD} -V _{SS}	Ta = 25 °C	4.75	5	5.25	V
Supply Voltage (V _{EE}) Typ.	V _{EE}	Ta = 25 °C	-	-23	-	
Input Voltage	V _{IL}	Ta = 25 °C	0	-	1.0	V
	V _{IH}	Ta = 25 °C	3.8	-	V _{dd}	V
Current Consumption	I _{DD}	V _{DD} =5 V Without Negative Voltage	--	6.5	--	mA
	I _{DD}	V _{DD} =5 V With Negative Voltage	--	85	--	mA

3.3 RECOMMENDED LC DRIVE VOLTAGE (VDD-VO)

VDD=5.0±0.25V

Temperature	STN	STN-H	FSTN POSITIVE	FSTN-H POSITIVE	FSTN NEGATIVE	FSTN-H NEGATIVE
T _a = -20°C	-	26.5	-	27.0	-	27.5
T _a = 0°C	25.5	25.5	26.2	26.2	26.0	26.0
T _a = 25°C	25.0	25.0	25.5	25.5	25.0	25.0
T _a = 50°C	24.0	24.0	24.0	24.0	24.2	24.2
T _a = 70°C	-	23.0	-	22.5	-	23.0

3.4 INTERFACE PIN ASSIGNMENT

Pin No.	Symbol	I/O	Function
1	D1	I/O	Bi directional data bus line 1
2	D2	I/O	Bi directional data bus line 2
3	D3	I/O	Bi directional data bus line 3
4	D4	I/O	Bi directional data bus line 4
5	DISPOFF	I	“L” : Display OFF “H” : Display ON
6	FRM	I	First Row Marker indicates the beginning of each display cycle
7	M	I	Control signal for A.C. drive
8	CL1	I	The CL1 latches the serial data in the shift registers
9	CL2	I	Clock signal for shifting the serial data
10	Vdd	-	Power Supply for logic circuit (+5V)
11	Vss	-	Ground
12	Vee	-	Power Supply for LC drive
13	Vo	-	Operating voltage for LC drive
14	FG	-	Frame Ground
15	N/C	-	No Connection
BL1	VLED+	-	LED+ backlight input voltage (from output of DC-AC inverter)
BL2	VLED-	-	LED- backlight input voltage (from output of DC-AC inverter)

3.5 BLOCK DIAGRAM

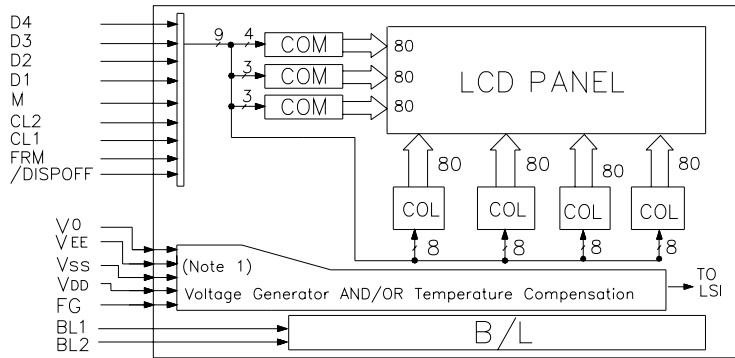

3.6 POWER SUPPLY CIRCUIT

• STN, STN-H, FSTN, FSTN-H
With temperature compensation

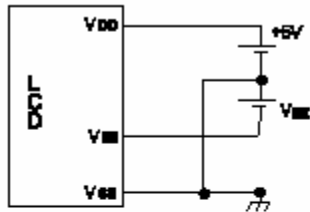

• STN, STN-H, FSTN, FSTN-H
With on-board negative
voltage generator

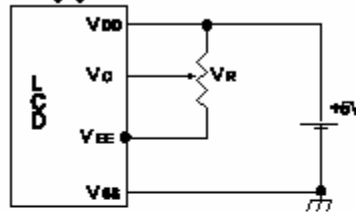

• STN, STN-H, FSTN, FSTN-H

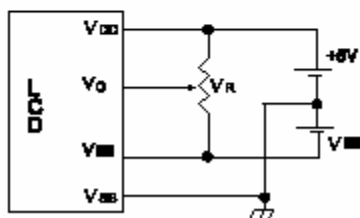

• STN, STN-H, FSTN, FSTN-H with on-board negative
voltage generator and temperature compensation

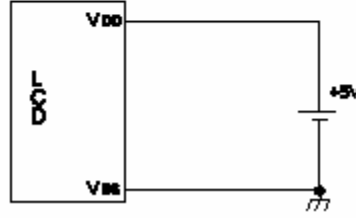

3.7 TIMING CHARACTERISTICS

Note: Please reference the manufacturer's data sheet for the ASLIC AX6086 controller.

4 OPTICAL SPECIFICATION

4.1 OPTICAL CHARACTERISTICS

Ta = 25 °C

Item	Symbol	Condition	Min	Typ	Max	Unit	Note
Viewing Angle	θ1	CR≥2	--	40	--	deg	1
	θ2	CR≥2	--	30	--	deg	1
	θ3	CR≥2	--	30	--	deg	2
	θ4	CR≥2	--	30	--	deg	2
Contrast Ratio	CR	∅=0° Ka=2	5	--	--	-	3
		∅=0° Ka=1.4	3	--	--		
Response Time	Tr	Ta = 25°C	--	200	--	ms	4
	Tf	Ta = 25°C	--	210	--		
Driving Method	Duty	1/240					
	Bias	1/14					
LCD Type	STN / Transmissive / Negative						
Viewing Direction	6 o'clock						

Ta = 25 °C

Item	Symbol	Condition	Min	Typ	Max	Unit	Note
Viewing Angle	θ1	CR≥2	--	50	--	deg	1
	θ2	CR≥2	--	35	--	deg	1
	θ3	CR≥2	--	35	--	deg	2
	θ4	CR≥2	--	35	--	deg	2
Contrast Ratio	CR	∅=0° Ka=2	5	--	--	-	3
		∅=0° Ka=1.4	3	--	--		
Response Time	Tr	Ta = 25°C	--	130	--	ms	4
	Tf	Ta = 25°C	--	340	--		
Driving Method	Duty	1/240					
	Bias	1/14					
LCD Type	FSTN / Transflective / Positive						
Viewing Direction	6 o'clock						

Note 1: definition of viewing angle θ_1 & θ_2

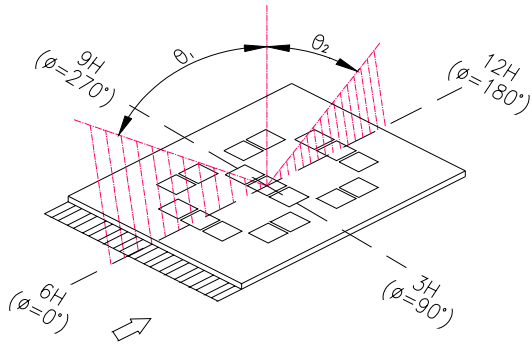

Note 2: definition of viewing angle θ_3 & θ_4

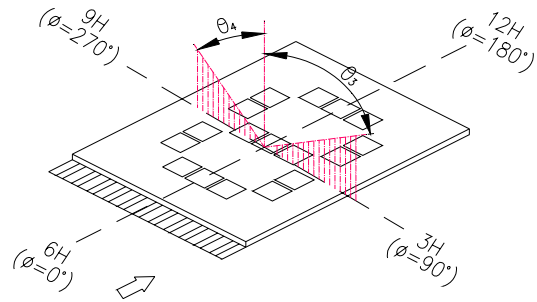

Note 3: definition of contrast ratio (CR)

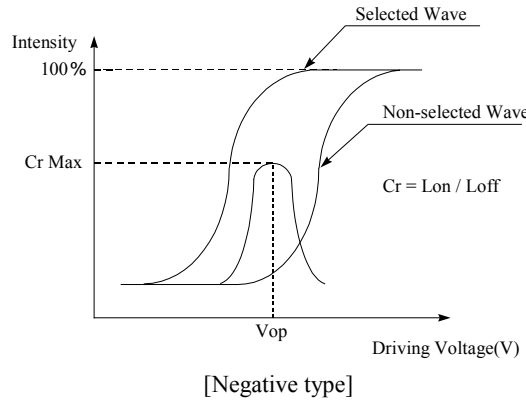
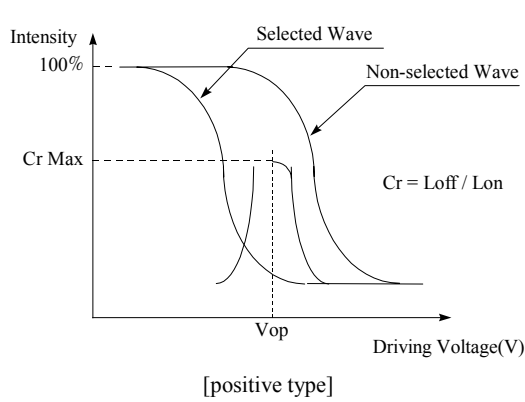

Note 4: definition of response time

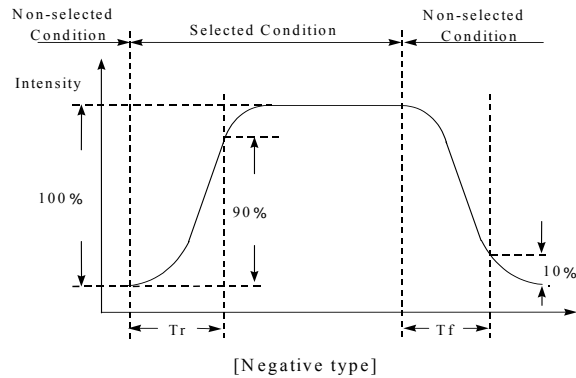
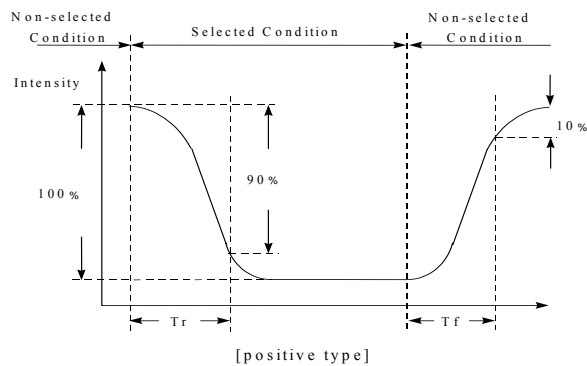

5 BACKLIGHT SPECIFICATION

5.1 BACKLIGHT CHARACTERISTICS

The backlight comprises of a light guide with LED, three LED emitters left and right.

Item	Symbol	Condition	Min	Typ	Max	Unit	Note
Supply Current	I		--	120	--	mA	
Forward Voltage	V _F	I _F = 60mA	--	5	--	V	
Average Luminous Intensity	STN		--	28	--	cd/m ²	1 (on LCD)
	FSTN-P		--	24	--		
	FSTN-N		--	32	--		
Life time		I _F = 120mA	-	40,000	-	hrs	3
Colour	White						

Note:

1. Average luminous intensity of 9 points
2. Brightness uniformity = (MAX-MIN) / MAX x 100
3. Half of the original brightness

6 QUALITY ASSURANCE SPECIFICATION

6.1 CONFORMITY

The performance, function and reliability of the shipped products conform to the Product Specification.

6.2 DELIVERY ASSURANCE

6.2.1 Delivery inspection standards

- IPC-AA610, class 2 electronic assemblies standard

6.2.2 Zone definition

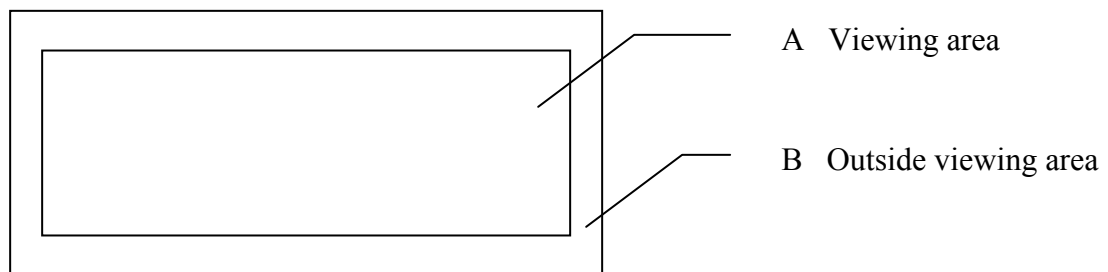

6.2.3 Visual inspection

- Inspect under 2x20W or 40W fluorescent lamp (approximately 3000 lux) leaving 25 to 30 cm between the module and the lamp and 30 cm between the module and the eye (measuring position).
- Appearance is inspected at the best contrast voltage (best contrast is adjusted considering clearness and crosstalk on screen).
- Inspect the module at 45° right and left, top and bottom.
- Use the optimum viewing angle during the contrast inspection.

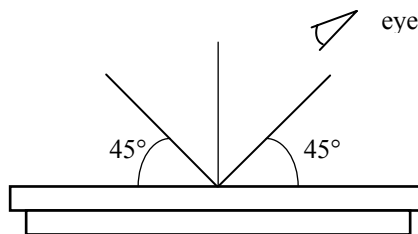

6.2.3.1 Standard of appearance inspection

Units: mm

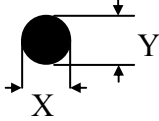
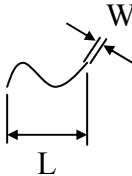
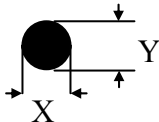
Class	Item	Criteria																																				
Minor	Packing & Label	Outside & inside package																																				
Critical		Presence of product no., lot no., quantity																																				
		Product must not be mixed with others and quantity must not be different from that indicated on the label																																				
Major	Dimension	Product dimensions must be according to specification and drawing																																				
Major	Electrical	Product electrical characteristics must be according to specification																																				
Critical	LCD Display	Missing lines or wrong patterns on LCD display are not allowed																																				
Minor	Black spot, white spot, dust	<p>Round type: as per following drawing $\varnothing = (X+Y)/2$</p>  <table border="1" style="margin-left: auto; margin-right: auto;"> <thead> <tr> <th colspan="3">Acceptable quantity</th> </tr> <tr> <th>Size</th> <th>Zone A</th> <th>Zone B</th> </tr> </thead> <tbody> <tr> <td>$\varnothing < 0.1$</td> <td>Any number</td> <td rowspan="4">Any number</td> </tr> <tr> <td>$0.1 < \varnothing < 0.2$</td> <td>2</td> </tr> <tr> <td>$0.2 < \varnothing < 0.25$</td> <td>1</td> </tr> <tr> <td>$0.25 < \varnothing$</td> <td>0</td> </tr> </tbody> </table> <p>Line type: as per following drawing</p>  <table border="1" style="margin-left: auto; margin-right: auto;"> <thead> <tr> <th colspan="4">Acceptable quantity</th> </tr> <tr> <th>Length</th> <th>Width</th> <th>Zone A</th> <th>Zone B</th> </tr> </thead> <tbody> <tr> <td>--</td> <td>$W \leq 0.02$</td> <td>Any number</td> <td rowspan="4">Any number</td> </tr> <tr> <td>$L \leq 3.0$</td> <td>$0.02 < W \leq 0.03$</td> <td>2</td> </tr> <tr> <td>$L \leq 2.5$</td> <td>$0.03 < W \leq 0.05$</td> <td></td> </tr> <tr> <td>--</td> <td>$0.05 < W$</td> <td>As round type</td> </tr> </tbody> </table> <p style="text-align: center;">Total acceptable quantity: 3</p>	Acceptable quantity			Size	Zone A	Zone B	$\varnothing < 0.1$	Any number	Any number	$0.1 < \varnothing < 0.2$	2	$0.2 < \varnothing < 0.25$	1	$0.25 < \varnothing$	0	Acceptable quantity				Length	Width	Zone A	Zone B	--	$W \leq 0.02$	Any number	Any number	$L \leq 3.0$	$0.02 < W \leq 0.03$	2	$L \leq 2.5$	$0.03 < W \leq 0.05$		--	$0.05 < W$	As round type
Acceptable quantity																																						
Size	Zone A	Zone B																																				
$\varnothing < 0.1$	Any number	Any number																																				
$0.1 < \varnothing < 0.2$	2																																					
$0.2 < \varnothing < 0.25$	1																																					
$0.25 < \varnothing$	0																																					
Acceptable quantity																																						
Length	Width	Zone A	Zone B																																			
--	$W \leq 0.02$	Any number	Any number																																			
$L \leq 3.0$	$0.02 < W \leq 0.03$	2																																				
$L \leq 2.5$	$0.03 < W \leq 0.05$																																					
--	$0.05 < W$	As round type																																				
Minor	Polariser scratch	Scratch on protective film is permitted Scratch on polariser: same as No. 1																																				
Minor	Polariser bubble	<p>$\varnothing = (X+Y)/2$</p>  <table border="1" style="margin-left: auto; margin-right: auto;"> <thead> <tr> <th colspan="3">Acceptable quantity</th> </tr> <tr> <th>Size</th> <th>Zone A</th> <th>Zone B</th> </tr> </thead> <tbody> <tr> <td>$\varnothing < 0.2$</td> <td>Any number</td> <td rowspan="4">Any number</td> </tr> <tr> <td>$0.2 < \varnothing < 0.5$</td> <td>2</td> </tr> <tr> <td>$0.5 < \varnothing < 1.0$</td> <td>1</td> </tr> <tr> <td>$1.0 < \varnothing$</td> <td>0</td> </tr> </tbody> </table> <p style="text-align: center;">Total acceptable quantity: 3</p>	Acceptable quantity			Size	Zone A	Zone B	$\varnothing < 0.2$	Any number	Any number	$0.2 < \varnothing < 0.5$	2	$0.5 < \varnothing < 1.0$	1	$1.0 < \varnothing$	0																					
Acceptable quantity																																						
Size	Zone A	Zone B																																				
$\varnothing < 0.2$	Any number	Any number																																				
$0.2 < \varnothing < 0.5$	2																																					
$0.5 < \varnothing < 1.0$	1																																					
$1.0 < \varnothing$	0																																					

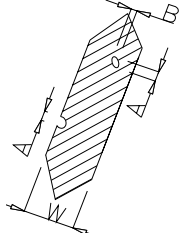
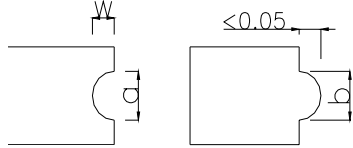
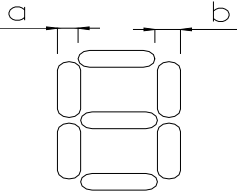
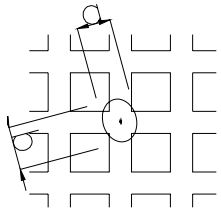
Class	Item	Criteria																												
Minor	Segment deformation	<p>1.a. Pin hole on segmented display W: segment width $\varnothing = (A+B)/2$</p>  <table border="1" style="margin-left: auto; margin-right: auto;"> <thead> <tr> <th colspan="2">Acceptable quantity</th> </tr> <tr> <th>Width</th> <th>\varnothing</th> </tr> </thead> <tbody> <tr> <td>$W \leq 0.4$</td> <td>$\varnothing \leq 0.2$ and $\varnothing \leq 1/2W$</td> </tr> <tr> <td>$W > 0.4$</td> <td>$\varnothing \leq 0.25$ and $\varnothing \leq 1/3W$</td> </tr> </tbody> </table> <p>Total acceptable quantity: 1 defect per segment Pin holes with \varnothing under 0.10 mm are acceptable</p>	Acceptable quantity		Width	\varnothing	$W \leq 0.4$	$\varnothing \leq 0.2$ and $\varnothing \leq 1/2W$	$W > 0.4$	$\varnothing \leq 0.25$ and $\varnothing \leq 1/3W$																				
Acceptable quantity																														
Width	\varnothing																													
$W \leq 0.4$	$\varnothing \leq 0.2$ and $\varnothing \leq 1/2W$																													
$W > 0.4$	$\varnothing \leq 0.25$ and $\varnothing \leq 1/3W$																													
Minor	Segment deformation	<p>1b. Pin hole on dot matrix display</p>  <table border="1" style="margin-left: auto; margin-right: auto;"> <thead> <tr> <th colspan="2">Acceptable quantity</th> </tr> <tr> <th>Size</th> <th></th> </tr> </thead> <tbody> <tr> <td>$a, b < 0.1$</td> <td>Any number</td> </tr> <tr> <td>$(a+b)/2 \leq 0.1$</td> <td>Any number</td> </tr> <tr> <td>$0.5 < \varnothing < 1.0$</td> <td>3</td> </tr> </tbody> </table> <p>Total acceptable quantity: 7</p> <p>2. Segments / dots with different width</p>  <table border="1" style="margin-left: auto; margin-right: auto;"> <thead> <tr> <th colspan="2">Acceptable</th> </tr> </thead> <tbody> <tr> <td>$a \geq b$</td> <td>$a/b \leq 4/3$</td> </tr> <tr> <td>$a < b$</td> <td>$a/b > 4/3$</td> </tr> </tbody> </table> <p>3. Alignment layer defect $\varnothing = (a+b)/2$</p>  <table border="1" style="margin-left: auto; margin-right: auto;"> <thead> <tr> <th colspan="2">Acceptable quantity</th> </tr> <tr> <th>Size</th> <th></th> </tr> </thead> <tbody> <tr> <td>$\varnothing \leq 0.4$</td> <td>Any number</td> </tr> <tr> <td>$0.4 < \varnothing \leq 1.0$</td> <td>5</td> </tr> <tr> <td>$1.0 < \varnothing \leq 1.5$</td> <td>3</td> </tr> <tr> <td>$1.5 < \varnothing \leq 2.0$</td> <td>2</td> </tr> </tbody> </table> <p>Total acceptable quantity: 7</p>	Acceptable quantity		Size		$a, b < 0.1$	Any number	$(a+b)/2 \leq 0.1$	Any number	$0.5 < \varnothing < 1.0$	3	Acceptable		$a \geq b$	$a/b \leq 4/3$	$a < b$	$a/b > 4/3$	Acceptable quantity		Size		$\varnothing \leq 0.4$	Any number	$0.4 < \varnothing \leq 1.0$	5	$1.0 < \varnothing \leq 1.5$	3	$1.5 < \varnothing \leq 2.0$	2
Acceptable quantity																														
Size																														
$a, b < 0.1$	Any number																													
$(a+b)/2 \leq 0.1$	Any number																													
$0.5 < \varnothing < 1.0$	3																													
Acceptable																														
$a \geq b$	$a/b \leq 4/3$																													
$a < b$	$a/b > 4/3$																													
Acceptable quantity																														
Size																														
$\varnothing \leq 0.4$	Any number																													
$0.4 < \varnothing \leq 1.0$	5																													
$1.0 < \varnothing \leq 1.5$	3																													
$1.5 < \varnothing \leq 2.0$	2																													
Minor	Colour uniformity	Level of sample for approval set as limit sample																												
Critical	Backlight	The backlight colour should correspond to the product specification																												
Critical		Flashing and or unlit backlight is not allowed																												
Minor		Dust larger than 0.25 mm is not allowed																												
Major	COB	Exposed wire bond pad is not allowed																												
Major		Insufficient covering with resin is not allowed (wire bond line exposed)																												
Minor		Dust or bubble on the resin are not allowed																												

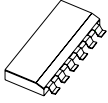
Class	Item	Criteria													
Major		No unmelted solder paste should be present on PCB													
Critical		Cold solder joints, missing solder connections, or oxidation are not allowed													
Minor		No residue or solder balls on PCB are allowed													
Critical		Short circuits on components are not allowed													
Minor	Tray particles	<table border="1"> <thead> <tr> <th></th> <th>Size</th> <th>Quantity</th> </tr> </thead> <tbody> <tr> <td rowspan="2">On tray</td> <td>$\varnothing < 0.2$</td> <td>Any number</td> </tr> <tr> <td>$\varnothing > 0.25$</td> <td>4</td> </tr> <tr> <td rowspan="2">On display</td> <td>$\varnothing \geq 0.25$</td> <td>2</td> </tr> <tr> <td>L = 3</td> <td>1</td> </tr> </tbody> </table>		Size	Quantity	On tray	$\varnothing < 0.2$	Any number	$\varnothing > 0.25$	4	On display	$\varnothing \geq 0.25$	2	L = 3	1
	Size	Quantity													
On tray	$\varnothing < 0.2$	Any number													
	$\varnothing > 0.25$	4													
On display	$\varnothing \geq 0.25$	2													
	L = 3	1													

7 RELIABILITY SPECIFICATION

7.1 RELIABILITY TESTS

Test Item	Test Condition	Evaluation and assessment
Operation at High Temperature and Humidity	40°C±2°C 90% RH for 240 hours	No abnormalities in function* and appearance**
High Temperature Operation	70°C±2°C for 240 hours	No abnormalities in function* and appearance**
Low Temperature Operation	-20°C±2°C for 240 hours	No abnormalities in function* and appearance**
High Temperature Storage	80°C±2°C for 240 hours	No abnormalities in function* and appearance**
Low Temperature Storage	-30°C±2°C for 240 hours	No abnormalities in function* and appearance**
Thermal Shock	-30°C (30 min)→ 25°C (5 min)→ 80°C (30 min)→25°C (5 min) 5 cycles.	No abnormalities in function* and appearance**
Vibration	Sweep for 1 minute at 10Hz, 55Hz, 10Hz, amplitude 1.5mm for 2 hours in the X, Y and Z directions.	No abnormalities in function* and appearance**
Drop Shock	Drop Shock	No abnormalities in function* and appearance**

7.2 LIFE TIME

Item	Description
1	Function, performance, appearance, etc. shall be free from remarkable deterioration within 50,000 hours under ordinary operating and storage conditions of room temperature (25±10 °C), normal humidity (45±20% RH), and in area not exposed to direct sunlight.
2	Function, performance, appearance, etc. shall be free from remarkable deterioration within 5,000 hours under ordinary operating and storage conditions of 70 °C temperature, normal humidity (45±20% RH), and in area not exposed to direct sunlight.

8 PART NUMBER DESCRIPTION FOR AVAILABLE OPTIONS

GRAPHIC PART NUMBER DESCRIPTION

LMR4055①②240G320③④⑤

① POLARISER OPTIONS

A = Reflective: Light background, no backlight.
 B = Transflective: Light background, with or without backlight.
 E = Transmissive: Dark background, with backlight
 (EL, LED or CCFL).

② LED BACKLIGHT COLOUR

G = Yellow-green
 A = Amber
 R = Red
 W = White

ROW X COLUMN DOT FORMAT

③ TEMPERATURE RANGE AND POWER SUPPLY

D = Standard Temperature range; negative supply voltage required.
 S = Standard Temperature range; on-board negative voltage generator.
 H = Wide temperature range; negative supply voltage required.
 W = Wide temperature range; on-board negative voltage generator.

④ FLUID TYPE AND COMPENSATION CIRCUIT

F = FSTN (Film Supertwisted Nematic).
 N = STN (Supertwisted Nematic).
 C = STN with on-board temperature compensation circuit.

⑤ BACKGROUND COLOR

B = Blue (transmissive polarizer).
 G = Grey (reflective and transflective).
 Y = Yellow background (reflective and transflective).
 X = 300+ NIT

Product No.	LMR4055	REV. A
-------------	---------	--------

Page	19 / 20
------	---------

9 HANDLING PRECAUTIONS

Safety

If the LCD panel breaks, be careful not to get the liquid crystal fluid in your mouth or in your eyes. If the liquid crystal touches your skin or clothes, wash it off immediately using soap and plenty of water.

Mounting and Design

Place a transparent plate (e.g. acrylic, polycarbonate or glass) on the display surface to protect the display from external pressure. Leave a small gap between the transparent plate and the display surface. When assembling with a zebra connector, clean the surface of the pads with alcohol and keep the surrounding air very clean. Design the system so that no input signal is given unless the power supply voltage is applied.

Caution during LCD cleaning

Lightly wipe the display surface with a soft cloth soaked with Isopropyl alcohol, Ethyl alcohol or Trichlorotrifluoroethane. Do not wipe the display surface with dry or hard materials that will damage the polariser surface. Do not use aromatic solvents (toluene and xylene), or ketonic solvents (ketone and acetone).

Caution against static charge

As the display uses C-MOS LSI drivers, connect any unused input terminal to VDD or VSS. Do not input any signals before power is turned on. Also, ground your body, work/assembly table and assembly equipment to protect against static electricity.

Packaging

Displays use LCD elements, and must be treated as such. Avoid strong shock and drop from a height. To prevent displays from degradation, do not operate or store them exposed directly to sunshine or high temperature/humidity.

Caution during operation

It is indispensable to drive the display within the specified voltage limit since excessive voltage shortens its life. Direct current causes an electrochemical reaction with remarkable deterioration of the display quality. Give careful consideration to prevent direct current during ON/OFF timing and during operation. Response time is extremely delayed at temperatures lower than the operating temperature range while, at high temperatures, displays become dark. However, this phenomenon is reversible and does not mean a malfunction or a display that has been permanently damaged. If the display area is pushed on hard during operation, some graphics will be abnormally displayed but returns to a normal condition after turning off the display once. Even a small amount of condensation on the contact pads (terminals) can cause an electro-chemical reaction which causes missing rows and columns. Give careful attention to avoid condensation.

Storage

Store the display in a dark place where the temperature is 25°C ± 10°C and the humidity below 50%RH. Store the display in a clean environment, free from dust, organic solvents and corrosive gases. Do not crash, shake or jolt the display (including accessories).

Product No.	LMR4055	REV. A
-------------	---------	--------

Page	20 / 20
------	---------